



iStor Networks, Inc.[®]

iStor Networks, Inc.

iS316 Hardware Reference Guide

Version 1.0

iS316HWRF1P00

Copyright

iStor Networks, Inc. makes no warranty of any kind with regard to this material, including, but not limited to, the implied warranties of merchantability and fitness for a particular purpose. iStor Networks, Inc. shall not be liable for errors contained herein or for incidental or consequential damages in connection with the furnishing, performance, or use of this material.

This document contains proprietary information, which is protected by copyright. No part of this document may be photocopied, reproduced, or translated into another language without the prior written consent of iStor Networks, Inc.

The information is provided "as is" without warranty of any kind and is subject to change without notice. The only warranties for iStor products and services are set forth in the express warranty statements accompanying such products and services. Nothing herein should be construed as constituting an additional warranty. iStor shall not be liable for technical or editorial errors or omissions contained herein.

Copyright © 2009 iStor Networks, Inc.; All Rights Reserved

Trademarks

Includes one or more of the following United States patents: 6,941,396; 7,353,306; 7,389,462; 7,460,473; 7,512,663 and 7,594,002. Other patents pending.

The iStor logo is a registered trademark of iStor Networks, Inc.

Adobe® and Acrobat® are trademarks of Adobe Systems, Incorporated.

Java™ is a U.S. trademark of Sun Microsystems, Incorporated.

Microsoft Windows is a U.S. registered trademark of Microsoft Corporation.

All other brand or product names are or may be trademarks or service marks, and are used to identify products or services, of their respective owners.

iStor Networks, Inc.
7585 Irvine Center Drive
Suite 250
Irvine, CA 92618

Safety Information

This product uses a lithium coin cell battery. The lithium coin cell battery is a long-life battery, and it is very possible that you will never need to replace it. However, should you need to replace it, consult your service documentation.



There is a danger of a new battery exploding if it is incorrectly installed. Replace the battery pack only with the same or equivalent type recommended by the manufacturer. Do not dispose of the battery along with household waste. Contact your local waste disposal agency for the address of the nearest battery deposit site.

CAUTION:

RISK OF EXPLOSION IF BATTERY IS REPLACED BY AN INCORRECT TYPE.
DISPOSE OF USED BATTERIES ACCORDING TO THE INSTRUCTIONS

Notice of Export Controls

Export of technical data contained in this document may require an export license from the United States government. Please contact iStor Networks, Inc. for any export compliance questions.

Document Revision Level

| Revision | Date | Description |
|---------------|---------------|-----------------|
| iS316HWRF1P00 | December 2009 | Initial Release |

Preface

This document is intended to assist users with installing the iS316 storage system from iStor Networks. This document assumes that users are computer literate, familiar with Storage Array Products, and have a basic understanding of storage products and concepts.

Typographic Conventions

Notes

Notes provide information that deserves special attention. They are preceded by:



Cautions

Cautions contain information which, if not followed, can cause damage to the integraStor storage system. They are preceded by:



Warnings

Warnings contain information which, if not followed, can cause damage to the integraStor storage system and to the person installing it. They are preceded by:



Related Documentation

In addition to this document, the following documents are available from iStor Networks.

- *iS316 Quick Start Guide* (document number iS316QS). This guide provides the information needed to get the iStor Networks iS316 storage array out of the box and operational with a direct connection to a host computer.
- *Management Center Software User's Guide* (document number iMCSWUG). This guide provides the information needed to configure and manage storage on the iS316 storage system using the integraSuite graphical user interface.
- *Command Line Interface User's Guide* (document number iSCLIUG). This guide provides the information needed to configure and manage storage on the iS316 storage system using the integraSuite's command line interface.
- *iStor Virtual Disk Services Guide* (document number D000045) describes how to use Microsoft Virtual Disk Services (VDS) to manage the iStor storage arrays.
- *iStor Terminology Guide* (document number iSTG). This guide is designed to assist you in the understanding of storage and SAN terminology that may be used in relation to the Management Center and the iS316 storage system. You may want to print this guide while reviewing the information and concepts in this document.

Contact Information

For more information about the iS316 storage system or iStor Networks, Inc., please contact us using any of the following methods:

- **Voice calls:** +1 (949) 753-8999
- **Email:** If you prefer, you can send information requests to our e-mail address: info@istor.com.
- **Fax calls:** You can also send your requests for information to our 24-hour fax number: (949) 753-1068
- **Web site:** Our Web site contains valuable information about our products. We encourage you to visit us at <http://www.istor.com>
- **Technical support:** The customer-satisfaction arm of iStor Networks is available by calling (800) 689-1409 and going to support or through email at support@istor.com

Contents

| | | |
|-------------------|---|-----------|
| Chapter 1 | Introduction | 1 |
| 1.1 | Product Models..... | 1 |
| 1.2 | Benefits and Features..... | 2 |
| 1.3 | System Overview | 3 |
| Chapter 2 | iS316 Physical Layout..... | 5 |
| 2.1 | Front Panel Components | 6 |
| 2.2 | Drive Carrier Components..... | 7 |
| 2.3 | Side and Bottom Panel Components..... | 7 |
| 2.4 | Rear Panel Components | 8 |
| Chapter 3 | Installing the iS316 Storage System..... | 11 |
| 3.1 | Site Considerations..... | 12 |
| 3.1.1 | General Considerations..... | 12 |
| 3.1.2 | Desktop or Shelf Installation | 12 |
| 3.1.3 | Rack-mount Guidelines..... | 13 |
| 3.2 | Safety Considerations..... | 13 |
| 3.3 | Unpacking the iS316 Storage System | 14 |
| 3.4 | Items Supplied by the User | 14 |
| 3.5 | Connecting to the iSCSI Data Ports | 15 |
| 3.6 | Connecting to the Management Port | 15 |
| 3.7 | Connecting the AC Power Cords..... | 16 |
| 3.8 | Installing the Hard Disk Drives..... | 16 |
| 3.9 | Powering-on the iS316 Storage System | 17 |
| Appendix A | Replacing and Upgrading FRUs..... | 19 |
| A.1 | Opening the iS316 Enclosure..... | 19 |
| A.2 | Upgrading or Replacing Memory | 20 |
| A.3 | Installing or Replacing SATA Drives..... | 23 |
| A.4 | Onboard Battery | 25 |
| A.5 | Replacing a Cooling Fan | 26 |
| A.6 | Replacing a Power Supply | 27 |
| Appendix B | Installing the System in a Rack..... | 29 |
| Index | | 33 |

List of Figures

| | |
|---|----|
| Figure 1-1. iS316 Storage System Diagram | 3 |
| Figure 2-1. Front View of the iS316 (shown without bezel) | 6 |
| Figure 2-2. Drive Slot Numbering | 7 |
| Figure 2-3. Drive Carrier Components (front view) | 7 |
| Figure 2-4. Rear View of the iS316 Storage System (4-port configuration shown) | 8 |
| Figure 2-5. Close-Up View of the iS316 Rear Panel | 9 |
| Figure 3-1. Front View of Drive Carrier | 16 |
| Figure 3-2. Installing the Hard Disk into the Drive Carrier (bottom view shown) | 16 |
| Figure A-1. Remove the Top Cover Side Screws | 19 |
| Figure A-2. Remove the Top Cover Thumb Screws | 19 |
| Figure A-3. Buffer Memory DIMM Sockets | 20 |
| Figure A-4. System Memory DIMM Sockets | 21 |
| Figure A-5. Removing a DIMM Module | 21 |
| Figure A-6. Inserting a DIMM Module | 22 |
| Figure A-7. Disconnecting the Drive Carrier | 23 |
| Figure A-8. Removing the Drive Carrier | 23 |
| Figure A-9. Inserting the Hard Disk Drive into the Drive Carrier (bottom view) | 24 |
| Figure A-10. Inserting the Drive Carrier into the Chassis | 24 |
| Figure A-11. Battery Pack Location | 25 |
| Figure A-12. Removable Fan Module | 26 |
| Figure A-13. Removing a Fan Module | 26 |
| Figure A-14. Power Supply Module | 27 |
| Figure A-15. Removing a Power Supply Module | 27 |
| Figure B-1. Rack-Mount Rail Kit | 29 |
| Figure B-2. Attaching the Side Rails to the Chassis | 29 |
| Figure B-3. Attaching the Mounting Rails to the Rack (square holes) | 30 |
| Figure B-4. Attaching the Mounting Rails to the Rack (round holes) | 30 |
| Figure B-5. Installing the Chassis into the Rack | 31 |

List of Tables

| | |
|---|----|
| Table 1-1. iS316 Storage System Models | 1 |
| Table 2-1. Front Panel Components | 6 |
| Table 2-2. Failure Conditions that Activate the Sys LED and Audio Alarm | 6 |
| Table 2-3. Drive Carrier LEDs | 7 |
| Table 2-4. Rear Panel Switches | 9 |
| Table 2-5. Data Port Speed and Port Activity LEDs | 9 |
| Table 2-6. RJ-45 Port Activity LEDs for the Management Port (J8) | 9 |
| Table 2-7. RJ-45 Port Speed LEDs for the Management Port (J8) | 9 |
| Table 3-1. User-Supplied Items to Perform the iS316 Storage System Installation | 14 |
| Table 3-2. Verifying Completion of the iS316 Storage System Power-on Process | 17 |

Chapter 1 Introduction

The iS316 storage system is an intelligent, high-performance multiple Gigabit Ethernet storage solution designed for businesses that want to improve the reliability, availability, serviceability, and performance of their storage systems. It provides a range of benefits and features from its ability to use familiar, proven, and widespread networking technologies like IP and Ethernet for storage solutions.

Based on an Internet Protocol-Storage Area Network (IP-SAN) architecture, the iS316 storage system is built around an iSNP8008 System-On-A-Chip, with the following features:

- Up to 16 internal Serial Advanced Technical Attachment (SATA) drives
- Up to 2 GB of system memory
- Up to 4 GB of buffer memory
- Four or eight Gigabit Ethernet local-area network (LAN) connectors
- A 10/100 Mbps management port
- An RS-232-C DB9 diagnostic port for troubleshooting purposes

Complete configuration and management are available through the intuitive, graphical-based iStor Management Center.



For the latest information about supported drives, consult the iStor-inAbleTM matrix on the iStor Web site: www.iStor.com.

1.1 Product Models

The iS316 storage system is available in various models. The models differ according to the number of host network interfaces. Table 1-1 lists the iS316 storage system models.

Table 1-1. iS316 Storage System Models

| Model | Host Network Interfaces |
|----------|--------------------------|
| iS316-04 | Four (4) GbE data ports |
| iS316-08 | Eight (8) GbE data ports |

1.2 Benefits and Features

- High-performance, low-latency iSCSI storage system, with a highly integrated, reliable, multi-function ASIC for fully featured, integrated storage virtualization
- Modular design with expansion up to 16 SATA disk drives
- Easy setup and configuration - can be placed anywhere on a 10BaseT, 100BaseT, or Gigabit Ethernet network for improved access to critical information
- In-band or out-of-band management via a direct connection or the Web
- Delivers Ethernet economics to storage for lower total cost of ownership and rapid deployment using known and trusted technologies
- Proven transport infrastructure for increased reliability, investment protection, and reduced training costs
- Scalability over long distances - ideal for remote data replication and disaster recovery
- Redundant cooling fans and hot-swappable, auto-sensing, load-sharing power supplies
- Battery pack ensures that a charged battery is on hand to preserve buffer cache contents if a power failure occurs. Contents are backed up for approximately 72 hours with the standard 2GB data cache (48 hours with the 4GB data cache option).

1.3 System Overview

Figure 1-1 shows a typical iS316 storage system configuration in a Storage Area Network (SAN). The SAN shown is an Ethernet network used solely for exchanging data between the customer's servers and the iS316 storage system. The Ethernet bandwidth used by the servers exchanging data with the iS316 storage system can be very high. Using a separate Ethernet to act as a SAN keeps that data from interfering with the customer's existing LAN and improves security.

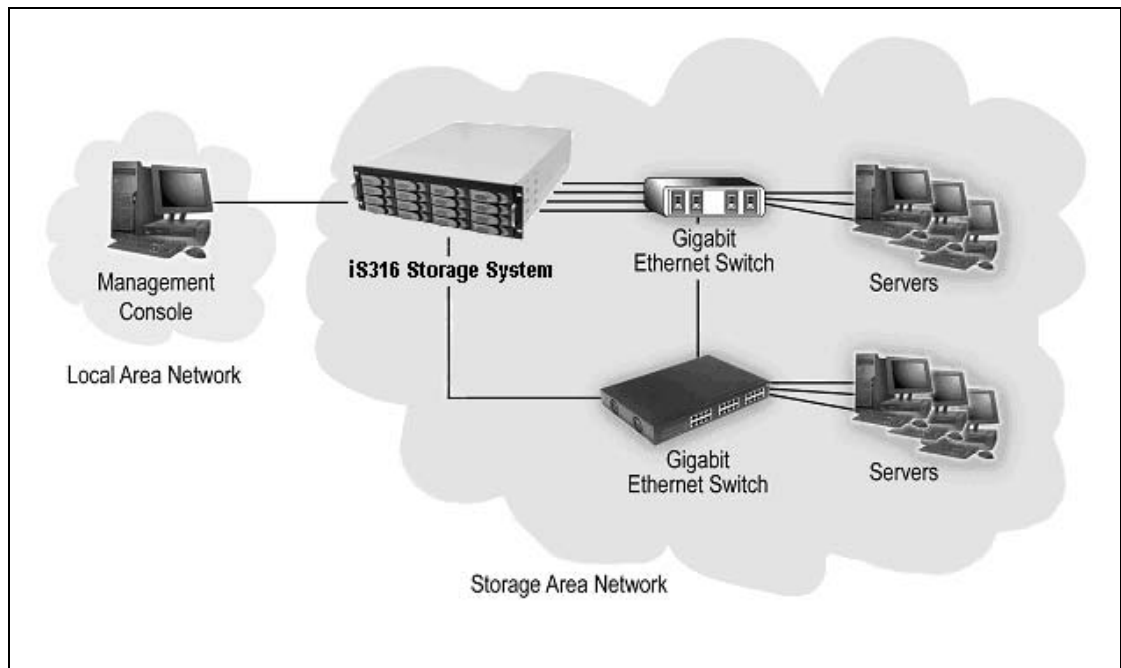

Figure 1-1. iS316 Storage System Diagram

This Page Left Intentionally Blank

Chapter 2 iS316 Physical Layout

This chapter describes the hardware components on the iS316 storage system. The topics covered in this chapter are:

- Section 2.1, Front Panel Components (page 6)
- Section 2.2, Drive Carrier Components (page 6)
- Section 2.3, Side and Bottom Panel Components (page 7)
- Section 2.4, Rear Panel Components (page 8)

2.1 Front Panel Components

The front of the iS316 storage system has the following components (see Figure 2-1):

- Sys LED - shows the iS316 power and ready status. See Table 2-1.
- Mute Button - allows you to mute the audio alarm when a Fault condition occurs. See Table 2-1.
- Sixteen (16) drive slots. See Figure 2-2
- A lock on the front bezel that protects access to the drives inside the unit.

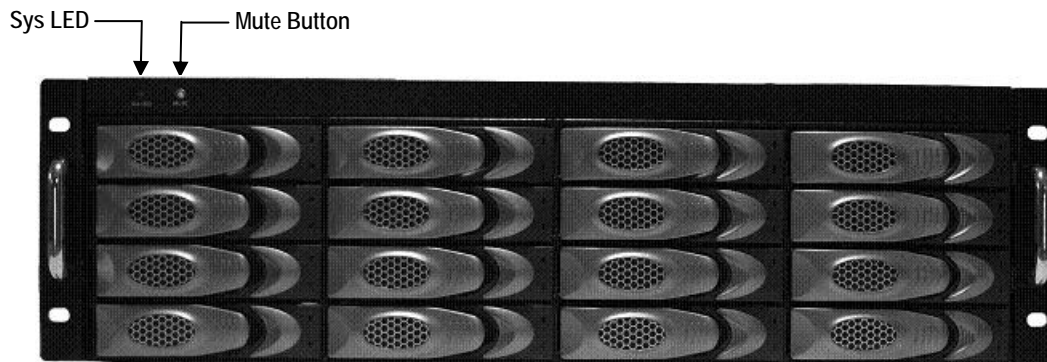

Figure 2-1. Front View of the iS316 (shown without bezel)

Table 2-1. Front Panel Components

| Control | Color | Description |
|-------------|---------------|--|
| Sys LED | Off | Array is powered off. |
| | Flashing Blue | The system is performing its startup procedure |
| | Solid Blue | The system is ready |
| | Red | A fault has occurred – refer to the system Event Log for detailed information – refer to Table 2-2 for more detailed information about the failure conditions that cause this LED to become illuminated. |
| Mute Button | N/A | Mutes the audio alarm when a Fault condition occurs |

Table 2-2. Failure Conditions that Activate the Sys LED and Audio Alarm

| Failure Condition | Description and Additional Information |
|----------------------|---|
| Power Supply Failure | The System Fault LED will be illuminated, and the audible alarm will sound. |
| Cooling Fan Failure | The System Fault LED will be illuminated, and the audible alarm will sound. |
| Battery Failure | The System Fault LED will be illuminated, and the audible alarm will sound. A system restart is required after the battery has been replaced. |
| Over Temperature | The System Fault LED will be illuminated, and the audible alarm will sound. |
| Software Failure | The System Fault LED will be illuminated, and the audible alarm will sound. |

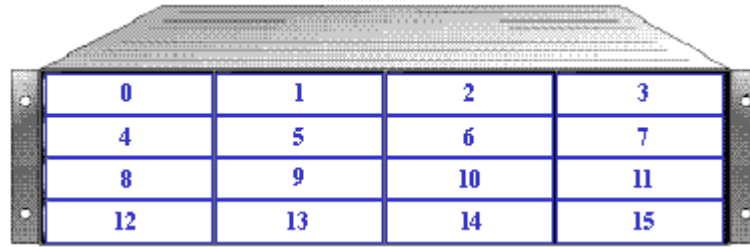

Figure 2-2. Drive Slot Numbering

2.2 Drive Carrier Components

The iS316 drive carrier has the following components (see Figure 2-3 and Table 2-3):

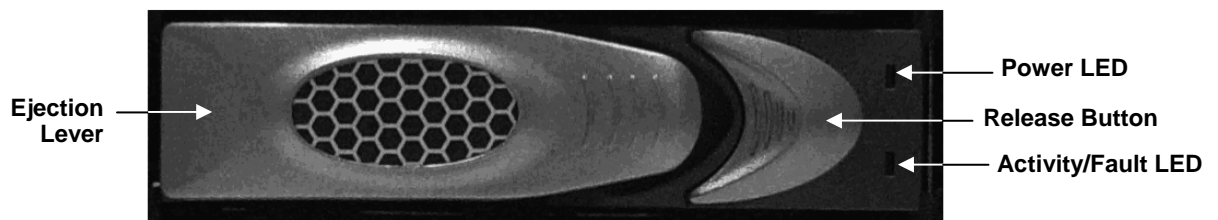

Figure 2-3. Drive Carrier Components (front view)

Table 2-3. Drive Carrier LEDs

| LED | Color | Description |
|----------------|---------------|---|
| Power | Off | The hard drive is missing or not powered on |
| | Solid Blue | The drive is powered on and available |
| Activity/Fault | Off | No activity or fault condition exists |
| | Flashing Blue | Data is being written to or read from the hard disk drive |
| | Solid Red | A fault condition exists with the hard drive |

2.3 Side and Bottom Panel Components

The left and right sides of the iS316 storage system enclosure have rails for rack-mounting the unit. Product information labels will be found on the side, bottom, or back of the unit. For rack-mount instructions, refer to Appendix B and the documentation for your rack.

2.4 Rear Panel Components

The rear of the iS316 storage system enclosure has the following components (see Figure 2-4 and Figure 2-5):

- Four or eight 1 Gigabit RJ-45 iSCSI data ports, depending on the array model. Each iSCSI data port has port speed and port activity LEDs (see Table 2-5).
- Diagnostic port (Diagnostic Port) - one 9600 bps RS-232-C DB9 diagnostic port is located to the right of the iSCSI data ports.
- Management port (Mgmt 10/100) - one 10/100 RJ-45 management is located to the right of the diagnostic port. The management port has port speed and port activity LEDs (see Table 2-6 and Table 2-7).
- Power switch and reset switch - are located above the I/O panel (see Figure 2-4 and Table 2-4).
- Cooling Fans - three hot-swappable cooling fans are located along the top of the panel. For information about how to replace a cooling fan, see section A-5.
- Power - two hot-swappable power supplies (each with one power receptacle) are located on the left side of the rear panel. For an explanation of the power receptacles, see section 3.7. For information about how to replace a power supply, see section A-6.

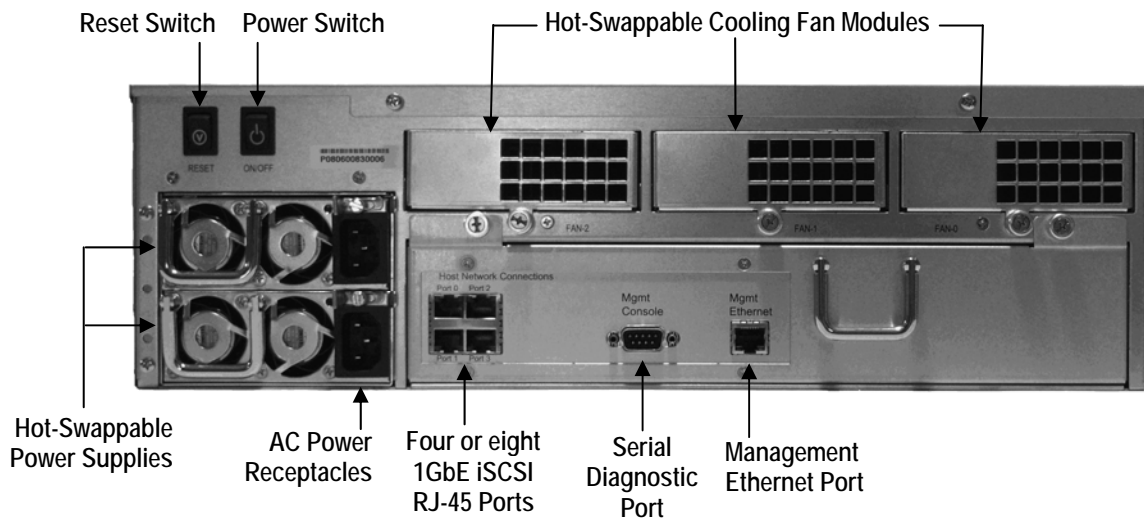

Figure 2-4. Rear View of the iS316 Storage System (4-port configuration shown)

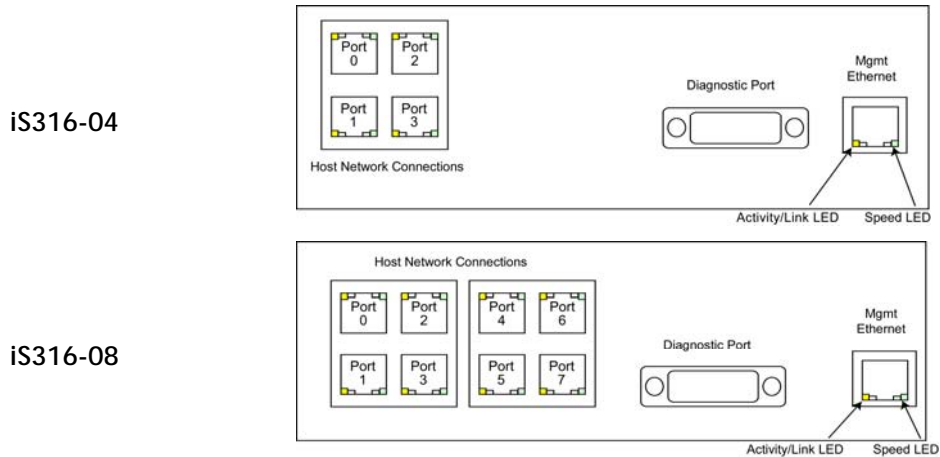

Figure 2-5. Close-Up View of the iS316 Rear Panel

Table 2-4. Rear Panel Switches

| Switch | Description |
|--------|---|
| Power | Applies power to the iS316 storage system. Pressing this switch for longer than 3 seconds removes power from the iS316 storage system and turns it off. |
| Reset | Resets the iS316 storage system. |

Table 2-5. Data Port Speed and Port Activity LEDs

|  | LED | Color | Description |
|---|------------|---|---|
| | Port Speed | Yellow | ON = link is operating at 1 Gbps. OFF = link is operating at either 10 Mbps or 100 Mbps. |
| Port Activity | Green | ON = link is operational. Flashing = data is being sent or received. | |

Table 2-6. RJ-45 Port Activity LEDs for the Management Port (J8)

| Color | Description |
|----------------|--|
| Green ON | Link is operational. |
| Green Blinking | Data is being transmitted or received on the RJ-45 port. |
| Yellow OFF | Connection has been established at 10 Mbps. |
| Yellow ON | Connection has been established at 100 Mbps. |

Table 2-7. RJ-45 Port Speed LEDs for the Management Port (J8)

| Color | Description |
|--------|---|
| OFF | Data is being sent or received at 10 Mbps. |
| Yellow | Data is being sent or received at 100 Mbps. |

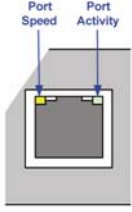
This Page Left Intentionally Blank

Chapter 3 Installing the iS316 Storage System

This chapter describes how to install the iS316 storage system. The topics covered in this chapter are:

- Section 3.1, Site Considerations (page 12)
- Section 3.2, Safety Considerations (page 13)
- Section 3.3, Unpacking the iS316 Storage System (page 14)
- Section 3.4, Items Supplied by the User (page 14)
- Section 3.5, Connecting to the iSCSI Data Ports (page 15)
- Section 3.6, Connecting to the Management Port (page 15)
- Section 3.7, Connecting the AC Power Cords (page 16)
- Section 3.8, Installing the Hard Disk Drives (page 16)
- Section 3.9, Powering-on the iS316 Storage System (page 17)

3.1 Site Considerations

The site where you install the iS316 storage system can affect its performance. Therefore, choose a site that conforms to the requirements in the following sections.

3.1.1 General Considerations

Observe the following considerations when selecting a location to install the iS316 storage system.

- The location should be fairly cool and dry for the acceptable temperature and humidity ranges.
- The location should be free of strong electromagnetic field generators (such as motors), vibration, dust, and direct exposure to sunlight.
- The location must provide sufficient airflow to the front and back of the iS316 storage system for correct cooling. Ventilation must be sufficient to exhaust heat from the rear of the equipment.
- The location should offer a power outlet within six feet (1.82 meters) of the iS316 storage system.
- The location should allow for at least six inches (152.3 mm) of space at the front and back of the iS316 storage system for ventilation.
- Do not place the iS316 storage system next to, on top of, or below any device that generates a significant amount of heat or will block the free flow of air through the iS316 ventilation slots.

3.1.2 Desktop or Shelf Installation

The iS316 storage system can be mounted on a desktop or shelf. Observe the following considerations for desktop or shelf installations.

- Select a sturdy, level surface that can support the iS316 storage system. A fully populated unit weighs approximately 85 lbs. (38.6 kg.).
- Allow enough ventilation space between the iS316 storage system and any other objects in the vicinity.
- Be sure not to block the air vents on the front and back of the iS316 storage system enclosure. Install the cables and power cords according to the procedures in the following sections.

3.1.3 Rack-mount Guidelines

The iS316 storage system can be mounted in a standard 19-inch rack. Observe the following considerations for rack installations. For information about installing the system in a rack, refer to Appendix B and to the documentation for the rack.

- All rack-mounting hardware must be carefully assembled to properly support the equipment. Follow the instructions in the documentation for the rack.
- The operating ambient temperature of rack-mounted equipment must not exceed the maximum rated ambient temperature indicated in this guide.
- The rack cabinet must provide sufficient airflow to the front and back of the iS316 storage system to maintain correct cooling. It must include ventilation sufficient to exhaust the heat generated by equipment installed in the rack.
- The rack must allow enough ventilation space between the iS316 storage system and any other objects in the vicinity. Do not block the air vents on the front and back of the iS316 enclosure. The air flow clearances specified in this guide must be maintained within the rack.
- The AC supply circuit for rack-mounted equipment must be capable of supplying the total current specified on all the labels of the rack-mounted equipment.
- All AC power supply connections must be properly grounded. To ensure the integrity of the earth connection, special attention must be given to connections that are not directly connected to the branch circuit (for example, power strips).

3.2 Safety Considerations

Observe the following guidelines to ensure safety:

- Do not wear loose clothing that could get caught in the chassis mounting hardware.
- Wear safety glasses when working under conditions that are hazardous to your eyes.
- Do not perform any action that creates a potential hazard to people or makes the rack or equipment unsafe.
- Do not work on the equipment or disconnect cables during a thunderstorm, when wearing a wool sweater or other heavy wool clothing, or when power is applied.
- Disconnect all power before installation and before connecting or disconnecting cables.
- Avoid hazards such as moist floor and ungrounded power-extension cables.
- To avoid damage to the iS316 storage system due to Electrostatic discharge (ESD), wear an ESD-preventive wrist strap. Connect the clip to an unpainted surface of the chassis frame to safely channel unwanted ESD voltages to ground. If no wrist strap is available, ground yourself by touching the metal part of the chassis.

3.3 Unpacking the iS316 Storage System

After receiving the iS316 storage system, perform the following steps to ensure that it and other contents arrived safely.

1. Inspect the outer shipping container for any damage that may have occurred in shipping. Report any sign of damage to the appropriate shipping agency.
2. Remove the iS316 storage system and cables from the shipping container.
3. Save the shipping container, foam, and antistatic bags in case you have to return the iS316 storage system. Returning the iS316 storage system in any other container is not advised.
4. Check the contents against the items referenced on the packing list. If any item is missing or damaged, notify a sales representative and/or the shipping agency.

3.4 Items Supplied by the User

Table 3-1 lists the additional items you must supply to perform the iS316 storage system installation. All users must provide the items in the first row of Table 3-1. Thereafter, the additional items required for installation depend on the user category into which you fit.

Table 3-1. User-Supplied Items to Perform the iS316 Storage System Installation

| User Category | User-Supplied Items |
|--|--|
| All Users | <ul style="list-style-type: none">▪ A PC with a Network Interface Card (NIC) that will act as the iSCSI initiator. (See Note 1.)▪ A PC with a NIC and Internet access that will access the management console. (See Note 1.)▪ One or more available AC outlets not controlled by a wall switch.▪ <i>Optional:</i> An Ethernet switch and Ethernet cable. If you want to use the iS316 storage system's Link Aggregation feature, the switch must support LAGs.▪ An IP address for each iS316 storage system host connection RJ-45 data port that will connect to your SAN.▪ An Ethernet cable for each iS316 storage system host connection RJ-45 data port that will connect to your SAN (the iS316 storage system auto-senses the cable type used). |
| Rack-Mount Users | <ul style="list-style-type: none">▪ A standard NEMA-compliant 19-inch rack.▪ Additional Mounting hardware for specific rack being used. |
| Note 1: For convenience, one PC with three installed NICs can be used instead of separate PCs. In this configuration, one NIC connects to the iS316 storage system management port, a second NIC connects to the Internet, and a third NIC is used with the iSCSI initiator. | |

3.5 Connecting to the iSCSI Data Ports

The iS316-04 storage system has four RJ-45 data ports, while the iS316-08 storage system has eight RJ-45 data ports. These ports connect to your SAN using either a straight-through or cross-over RJ-45 Ethernet cable (the iS316 storage system auto-senses the type of cable used). One cable is needed for each RJ-45 data port.

1. Attach one end of an Ethernet cable to host network connection port 0 on the iS316 storage system back panel (see the top or middle figure in Figure 2-5 on page 9). Connect the other end of the cable to your SAN or host system.
2. To connect additional host network connection ports to your SAN, repeat step 1 using another Ethernet cable and the next available iS316 storage system port in sequence (port 1, then port 2, and so on). Do not skip ports when making these connections.

3.6 Connecting to the Management Port

Connecting a PC to the management port lets you configure and manage the iS316 storage system. This connection is made using a PC with an installed NIC and either a cross-over cable (if connecting directly to the management port) or a straight-through cable (if connecting to the management port using a hub or switch).

To receive email alerts from the iS316 storage system, be sure the management port can communicate via Ethernet with your mail server.

1. Connect either end of an Ethernet cable to a NIC installed in a PC.
2. Connect the other end of the cable into the iS316 storage system **Mgmt 10/100** port. This port is located to the right of the diagnostic port on the back panel (see Figure 2-5 on page 9).



Do not connect one NIC to the management and host network connection ports. Connect one NIC to the management port and connect another NIC in the same PC or a different PC to the host network connection port(s).

3.7 Connecting the AC Power Cords

The iS316 storage system has two power receptacles. Both must be used to connect the iS316 to an AC outlet:

1. Plug the female end of one power cord into one of the 3-pronged power connectors on the rear of the iS316 storage system. Plug the other end of the power cord into a working AC outlet that is not controlled by a wall switch.
2. Repeat the previous step using the second power cable and power receptacle on the iS316 storage system. For best results, both power receptacles should be on a different circuit.



Although the iS316 storage system can operate temporarily with only one AC power connection, an audio alarm will sound until both power receptacles are used. To silence the audio alarm, press the Mute button on the front panel. For more detailed information, refer to Section 2.1

3.8 Installing the Hard Disk Drives

Use the following procedure to install the SATA drives into the drive carriers.

1. Remove each empty drive carrier by pushing the gray release button to the right and pulling the ejection lever forward, then sliding the drive carrier out of the enclosure.

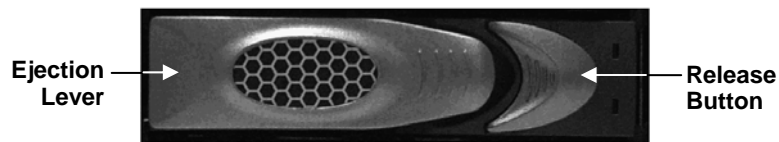

Figure 3-1. Front View of Drive Carrier

2. Place the hard drive into the drive carrier and attach it using four mounting screws through the bottom of the drive carrier (two screws on each side).

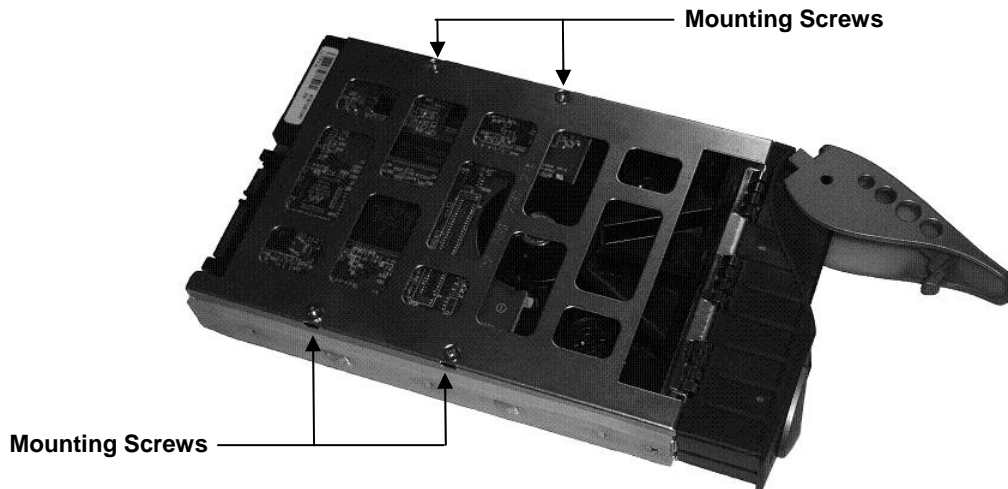

Figure 3-2. Installing the Hard Disk into the Drive Carrier (bottom view shown)

3. Insert the assembled drive carrier into the iS316 enclosure until the latching mechanism engages with the chassis, and then press the Ejection Lever until the latch clicks to secure the drive carrier in place.
4. Repeat the steps above for all other drives.

Refer to Section A-3 in Appendix A for more detailed information about installing the hard disk drives.

3.9 Powering-on the iS316 Storage System

To power-on the iS316 storage system, press the power switch on the back panel. When the iS316 storage system powers-on, the following actions occur:

- The **Sys LED** on the front panel flashes blue.
- The iS316 storage system runs its power-on procedure (2-to-5 minutes), then the **Sys LED** turns solid blue and drive LEDs may flash.

The completion of the power-on process can be verified as indicated in Table 3-2.

Table 3-2. Verifying Completion of the iS316 Storage System Power-on Process

| If the iS316 Storage System... | Verify the Power-on Process by... |
|--|---|
| The Sys LED is flashing blue | Wait approximately five minutes after powering-on the iS316 storage system |
| The Sys LED is solid blue | The Sys LED turns solid blue when the system startup process completes. If the LED turns red, reboot the iS316 storage system. If the problem persists, contact Technical Support. |
| Diagnostic port is connected to a PC via a diagnostic cable. | The message RCP sequence complete appears on the PC monitor. After verifying this message, disconnect the PC from the diagnostic port. |

After the iS316 storage system powers-on for the first time, it automatically loads the factory-default configuration settings. If necessary, you can use the iStor Management Center to change these settings to suit your requirements. For a description of the array's factory-default configuration settings and how to change them, refer to the *Management Center User's Guide*.

This Page Left Intentionally Blank

Appendix A Replacing and Upgrading FRUs

This appendix describes how to replace or upgrade the Field Replaceable Units (FRUs) in your iS316 storage system. FRUs that can be replaced or upgraded include:

- System and buffer memory
- SATA drives
- Onboard battery
- Fans
- Power supplies

A.1 Opening the iS316 Enclosure

Use the following procedure to remove and replace the top cover of the iS316 chassis.

1. Use a Phillips™ screwdriver to remove the small screw on each side, as shown in Figure A-1.



Figure A-1. Remove the Top Cover Side Screws

2. Remove the thumb screws on the rear panel, as shown in Figure A-2.

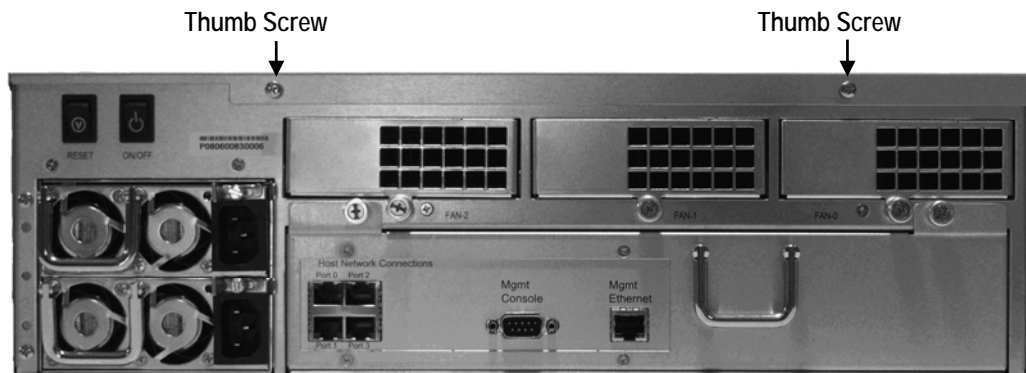

Figure A-2. Remove the Top Cover Thumb Screws

3. Slide the top cover to the rear, then lift it off.
4. To replace the top cover, reverse the above steps.

A.2 Upgrading or Replacing Memory

The iS316 storage system supports up to 2 GB of buffer memory and up to 4 GB of system memory using four Dual In-line Memory Module (DIMM) sockets on the iS316 storage system Controller:

- Two DIMM sockets (J36 and J37) are for buffer memory.
- Two DIMM sockets (J38 and J39) are for system memory.

All four DIMM sockets accommodate standard 184-pin Double Data Rate (DDR) PC2700 (DDR333) DIMMs that support ECC. However, the iS316 storage system can be used with only one DIMM module installed for buffer memory and system memory.

To upgrade or replace memory, use the following procedure.

1. Perform an orderly shutdown of the iS316 storage system and remove the power cord from the back panel.
2. Attach an ESD-preventive wrist strap.
3. Open the enclosure to access the iS316 storage system Controller (see section A.1).
4. Locate the DIMM socket where you will be removing or installing the DIMM (see Figures A-3 and A-4).

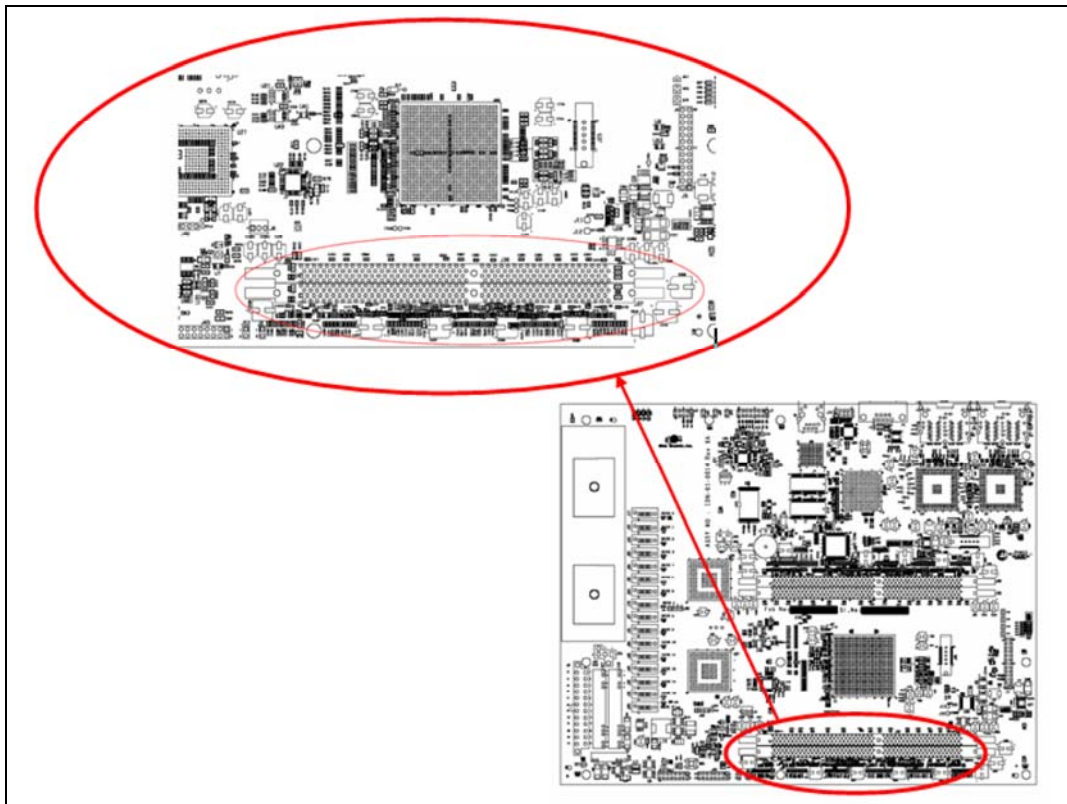

Figure A-3. Buffer Memory DIMM Sockets

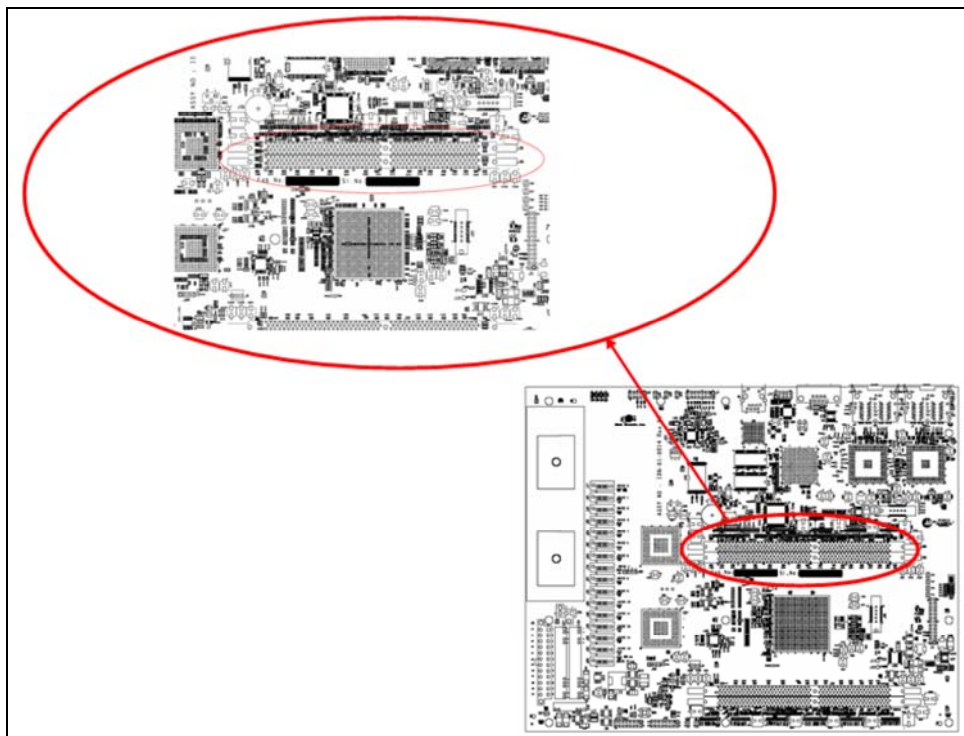

Figure A-4. System Memory DIMM Sockets

5. To remove a DIMM, carefully push the socket latches found on either side of the DIMM socket, then pull the DIMM out of the socket (see Figure A-5). The latches hold the DIMM tightly, so be careful not to damage the socket.

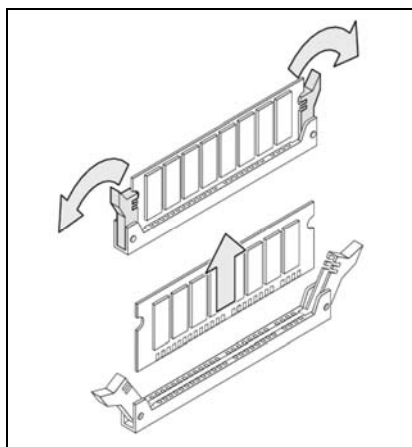

Figure A-5. Removing a DIMM Module

6. Hold the new DIMM above the DIMM socket, so its polarization notch is located at the right end of the DIMM socket.



If only one DIMM is used for buffer memory, install it in slot J36 (the inside connector of the two buffer memory sockets). If only one DIMM is used for system memory, install it in slot J38 (the inside connector of the two system memory sockets).

7. Slowly insert the new DIMM by sliding the end with the metal fingers into the DIMM socket (see Figure A-6). Stop sliding when the DIMMM is securely seated in the socket.

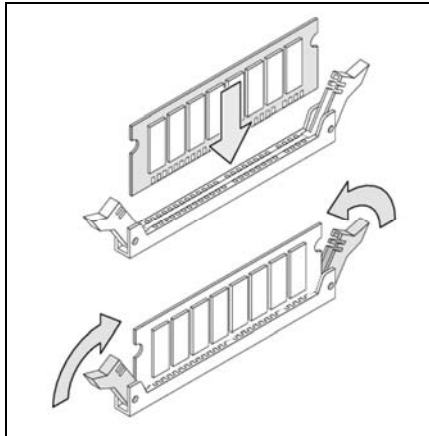

Figure A-6. Inserting a DIMM Module

8. Snap the latches into place. Do not use excessive force, because the socket might break.
9. Replace the enclosure (see section A.1).
10. Power on the iS316 storage system. If error messages relating to memory are displayed, remove the DIMM and reinstall it, making sure to seat the DIMM firmly in its socket.



Before replacing a DIMM, be sure that the system has been shut-down gracefully first, and that the battery is not sustaining buffer memory (the amber LED at location D42 should be off). Otherwise, the system may not be able to restart properly when it is powered on.

A.3 Installing or Replacing SATA Drives

To install or replace SATA drives, use the following procedure.

1. Push the Release Button to the right, then pull the Ejection Lever forward.

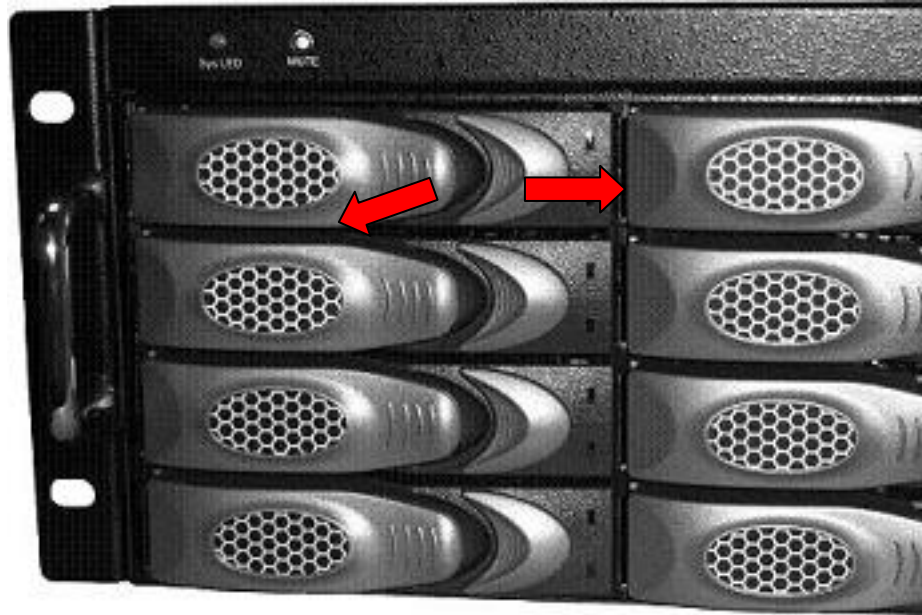

Figure A-7. Disconnecting the Drive Carrier

2. Remove the Drive Carrier from the chassis by sliding it forward.

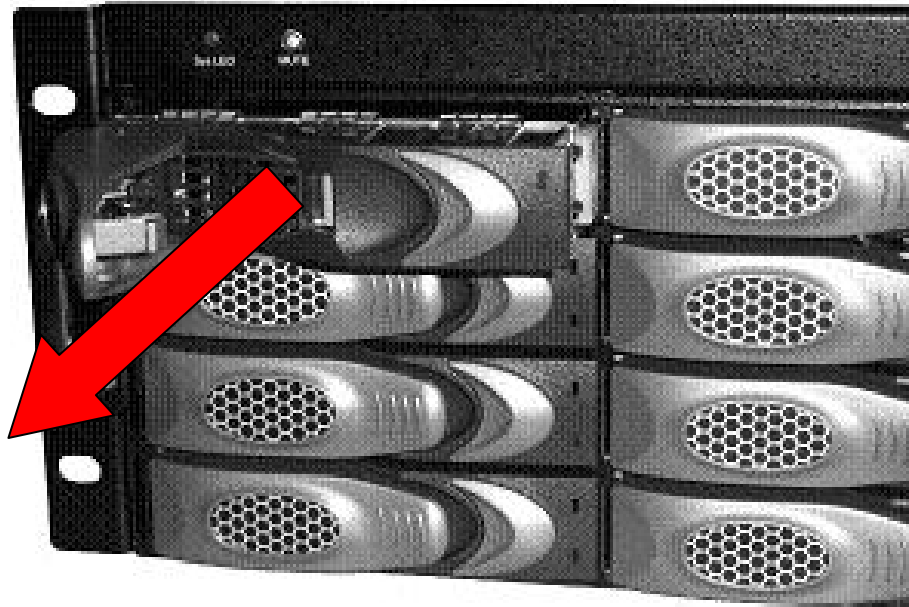

Figure A-8. Removing the Drive Carrier

3. If you are replacing an existing hard disk drive, remove the four mounting screws from the bottom of the drive carrier (two on each side) and remove the new hard disk drive from the drive carrier.
4. Insert the new hard disk drive in the drive carrier and secure it with four screws from the bottom of the drive carrier.

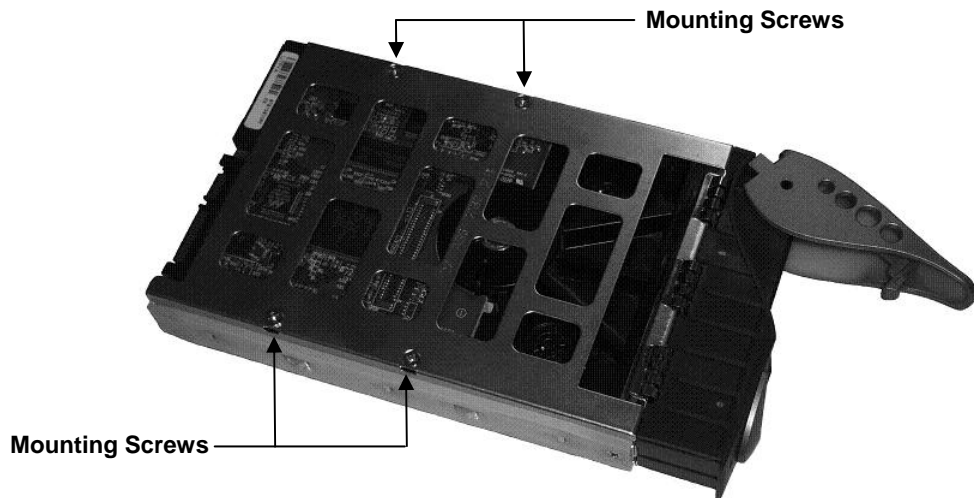

Figure A-9. Inserting the Hard Disk Drive into the Drive Carrier (bottom view)

5. Gently insert the drive carrier into the chassis until the Ejection Lever locking mechanism contacts the chassis, and then press the Ejection Lever until it locks the drive carrier in place.

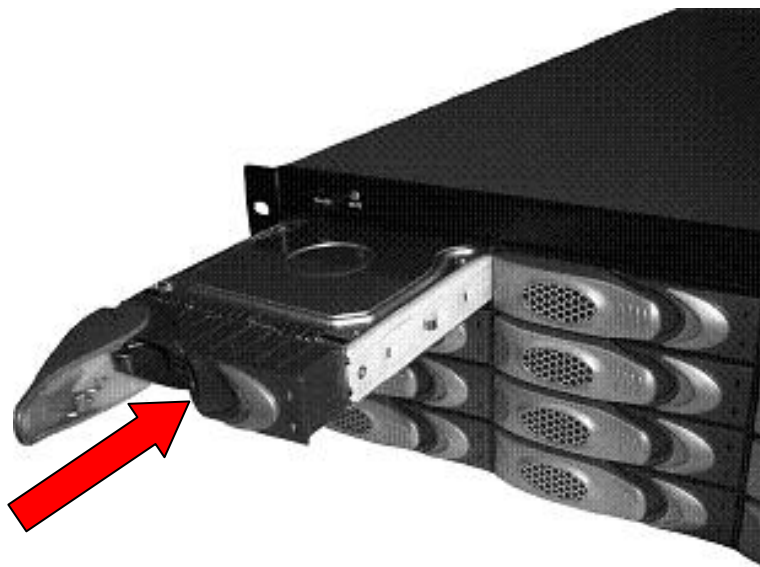

Figure A-10. Inserting the Drive Carrier into the Chassis

A.4 Onboard Battery

The iS316 controller requires a shrink-wrapped battery pack to be attached and fully charged before RAID operations can be performed. The battery pack is a removable lithium-ion pack, with embedded safety circuits and attached harness.

The battery pack connects to the iS316 controller using a 3-pin locking connector at J35 (see Figure A-11). This connector consists of 3M Dual Lock re-closable fastener strips, which allow easy field replacement of the battery pack, if required.

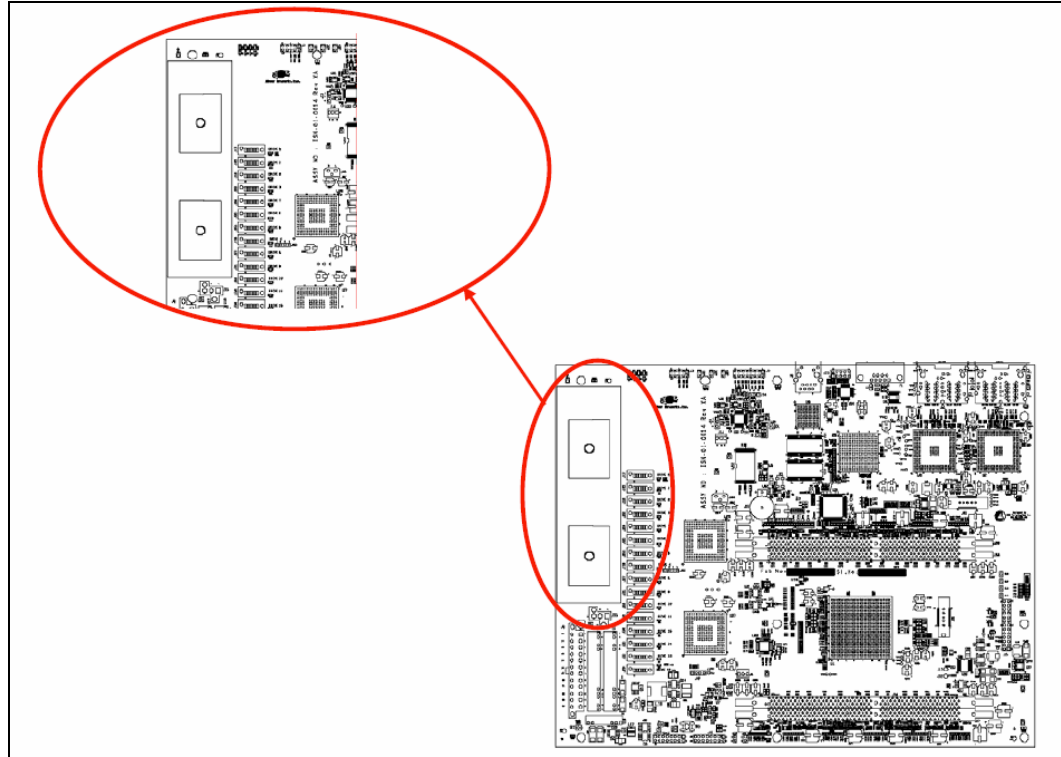

Figure A-11. Battery Pack Location

A.5 Replacing a Cooling Fan

The iS316 storage system contains three (3) hot-swappable cooling fans that are accessible from the rear panel, without needing to remove the chassis from the rack. Figure A-12 shows the fan module removed from the chassis.



Figure A-12. Removable Fan Module

Use the following procedure to replace a cooling fan (see Figure A-13):

1. Loosen the captive thumb screw for the fan module that you wish remove.
2. Pull the failed fan module out of the chassis
3. Insert the replacement fan module into the chassis
4. Tighten the captive thumb screw

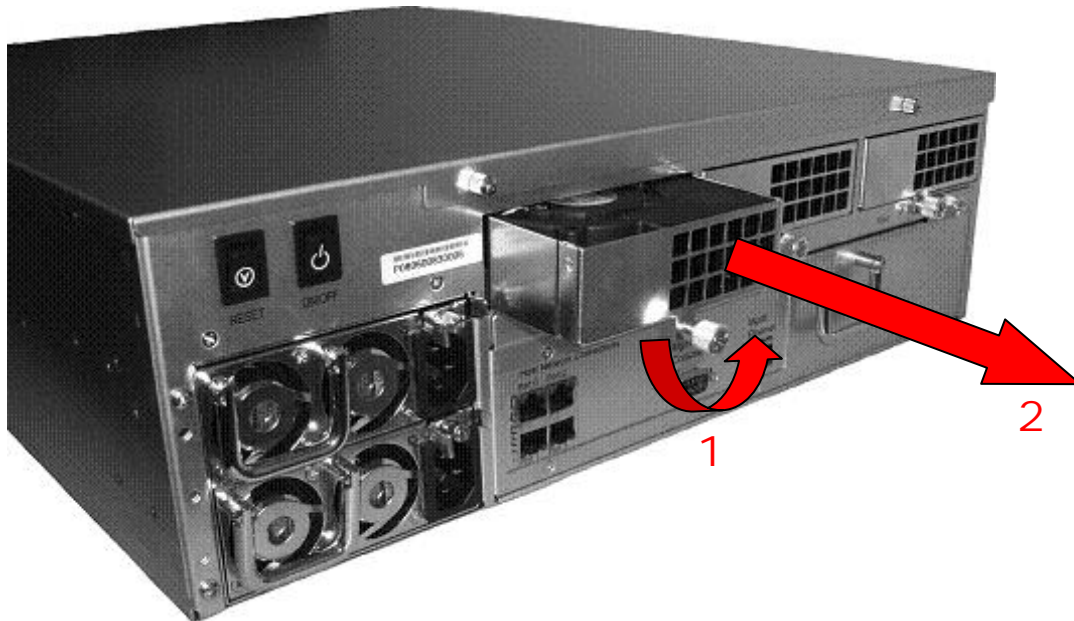

Figure A-13. Removing a Fan Module

A.6 Replacing a Power Supply

The iS316 storage system contains two (2) hot-swappable power supplies that are accessible from the rear panel, without needing to remove the chassis from the rack. Figure A-14 shows the fan module removed from the chassis.



Figure A-14. Power Supply Module

Use the following procedure to replace a power supply module, after disconnecting the AC power cord from the power supply module (see Figure A-15).

1. Loosen the captive thumb-screw located above the power receptacle
2. Pull the failed power supply out of the chassis
3. Insert the replacement fan module into the chassis
4. Tighten the captive thumb-screw

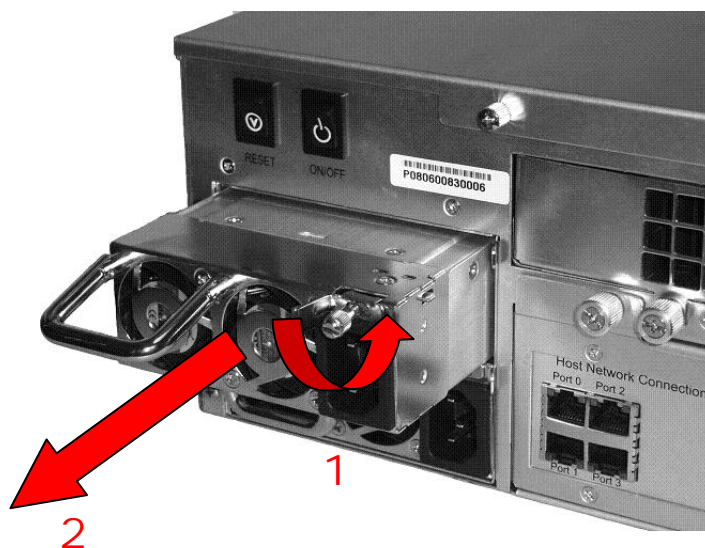

Figure A-15. Removing a Power Supply Module

This Page Left Intentionally Blank

Appendix B Installing the System in a Rack

This appendix describes how to install the iS316 storage system in a rack. The iS316 storage system can be mounted in a standard 19-inch rack. Use the following procedure, along with the documentation for the rack, to install the iS316 storage system in a rack.



The rack cabinet must provide sufficient airflow to the front and back of the iS316 storage system to maintain correct cooling. It must include ventilation sufficient to exhaust the heat generated by equipment installed in the rack.

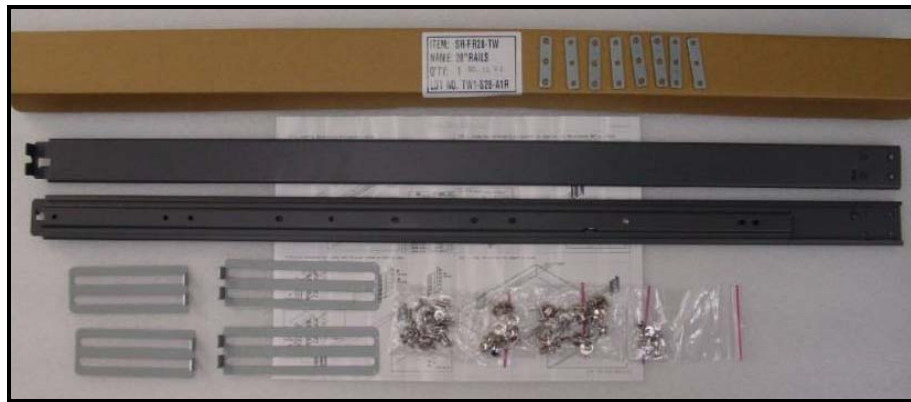

Figure B-1. Rack-Mount Rail Kit

Before starting, be sure the iS316 storage system is turned off and its power cords are removed from the rear of the unit.

1. Attach the mounting hardware to the left and right sides of the iS316 chassis, as shown in the following illustration.

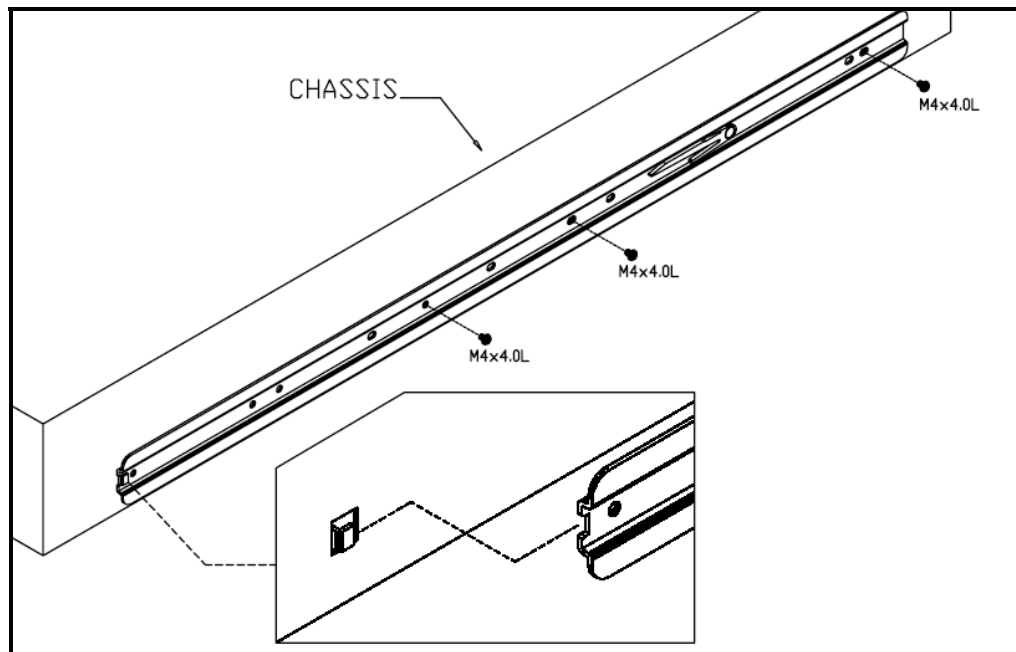

Figure B-2. Attaching the Side Rails to the Chassis

- Secure with the mounting hardware to the rack. Refer to Figure B-2 for rack rails with square holes, or Figure B-3 for rack rails with round holes.

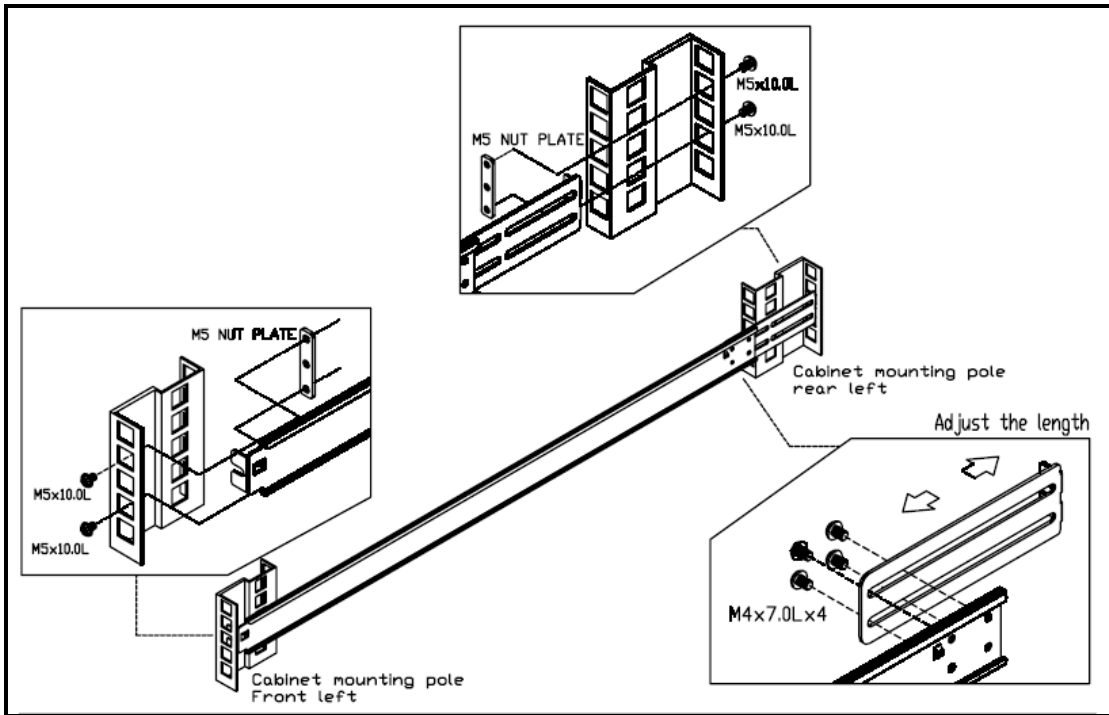

Figure B-3. Attaching the Mounting Rails to the Rack (square holes)

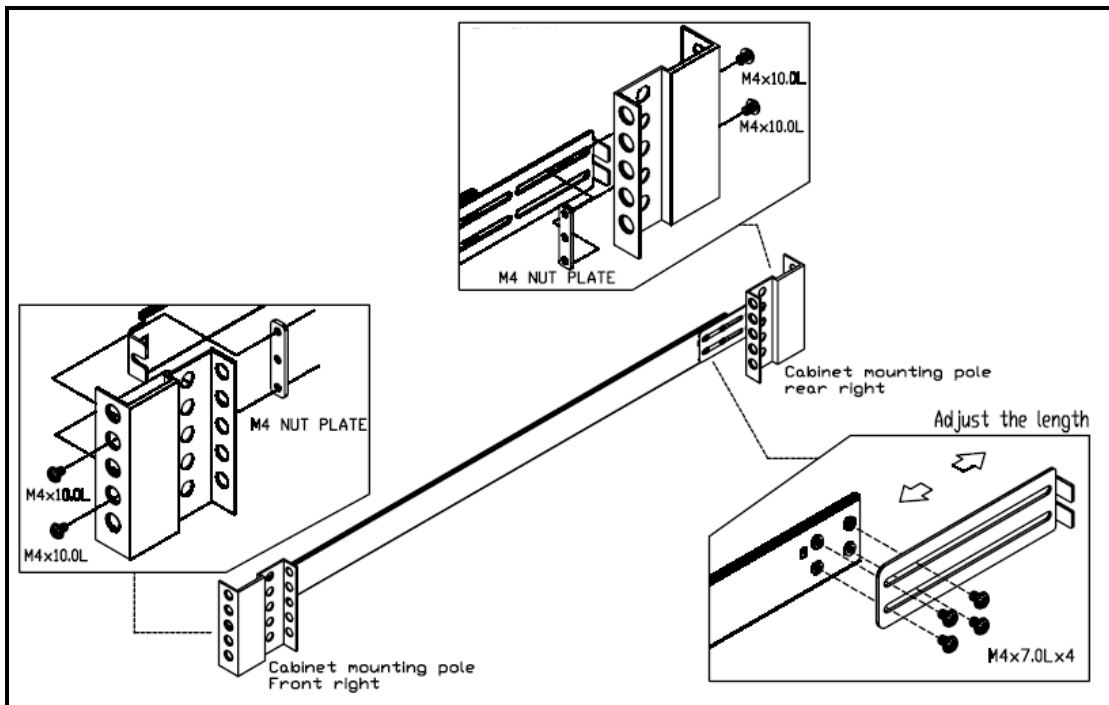

Figure B-4. Attaching the Mounting Rails to the Rack (round holes)

3. With the assistance of another person, insert the iS316 chassis into the rack.

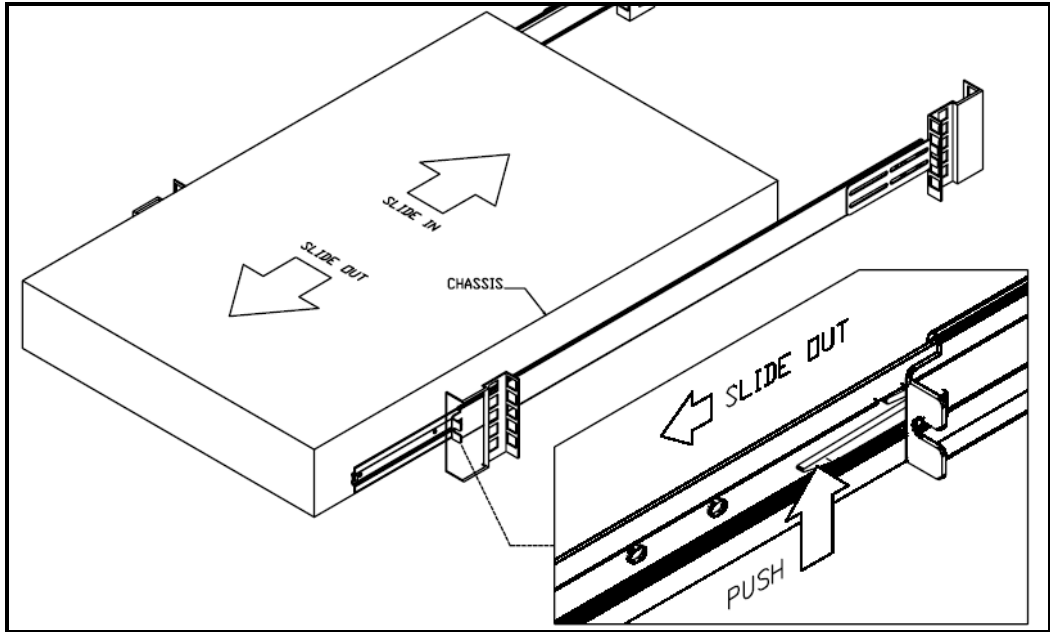

Figure B-5. Installing the Chassis into the Rack

Index

B

Benefits · 2
Buffer memory, upgrading or replacing · 20

C

Connecting
 power cord · 16
Connecting to
 host network ports · 15
 management port · 15
Conventions · iv
Cooling fans, installing or replacing · 26

D

Drive Carrier
 installing hard disk drives · 16
Drives
 installing or replacing · 23

E

Enclosure
 damage to · 14
 front panel · 6, 7
 opening the top cover · 19
 rear panel · 8
Enclosure LEDs · 6, 7

F

Fans, installing or replacing · 26
Features · 2
Front panel components · 6, 7
Front panel LEDs · 6, 7

H

Hard Disk Drives
 installing · 16
Host network port connections · 15

I

Installation
 connecting the power cord · 16
 connecting to host network ports · 15
 connecting to management port · 15
 hard disk drives · 16

 safety considerations · 13
 site considerations · 12
 unpacking the iS316 storage system · 14
 user-supplied items · 14

Installing

 drives · 23
 fan modules · 26
 memory · 20
 onboard battery · 25

iS316 storage system

 back view · 9
 benefits · 2
 connecting to host network ports · 15
 features · 2
 front panel components · 6, 7
 models · 1
 power-on · 17
 rear panel components · 8
 system overview · 3
 unpacking · 14

L

LEDs

 on front panel · 6, 7
 port activity · 9
 port speed · 9

M

Management port connection · 15
Memory
 upgrading or replacing · 20
Models · 1

O

Onboard battery · 25
Opening
 enclosure top cover · 19
Opening the enclosure · 19

P

Port activity LEDs · 9
Port speed LEDs · 9
Power cord connection · 16
Powering-on the iS316 storage system · 17

R

- Rear panel components · 8
- Rear view of iS316 storage system · 9
- Replacing
 - drives · 23
 - fan modules · 26
 - memory · 20
 - onboard battery · 25

S

- Safety considerations · 13
- Site considerations · 12
- System memory, upgrading or replacing · 20
- System overview · 3

T

- Top Cover
 - opening · 19
- Typographic conventions · iv

U

- Unpacking the iS316 storage system · 14
- Upgrading
 - drives · 23
 - memory · 20
- User-supplied items · 14