



**iStor Networks, Inc.<sup>®</sup>**

**iStor Networks, Inc.**

**iS512-Series Hardware Reference Guide**

**Version 1.5**

**iS512HWRF1P50**

## Copyright

iStor Networks, Inc. makes no warranty of any kind with regard to this material, including, but not limited to, the implied warranties of merchantability and fitness for a particular purpose. iStor Networks, Inc. shall not be liable for errors contained herein or for incidental or consequential damages in connection with the furnishing, performance, or use of this material.

This document contains proprietary information, which is protected by copyright. No part of this document may be photocopied, reproduced, or translated into another language without the prior written consent of iStor Networks, Inc.

The information is provided "as is" without warranty of any kind and is subject to change without notice. The only warranties for iStor products and services are set forth in the express warranty statements accompanying such products and services. Nothing herein should be construed as constituting an additional warranty. iStor shall not be liable for technical or editorial errors or omissions contained herein.

Copyright © 2008-2010, iStor Networks, Inc.

## Patents and Trademarks

Includes one or more of the following United States patents: 6,941,396; 7,353,306; 7,389,462; 7,460,473; 7,512,663 and 7,594,002. Other patents pending.

The iStor logo is a registered trademark of iStor Networks, Inc.

Adobe® and Acrobat® are trademarks of Adobe Systems, Incorporated.

Java™ is a U.S. trademark of Sun Microsystems, Incorporated.

Microsoft Windows is a U.S. registered trademark of Microsoft Corporation.

Oracle® is a registered U.S. trademark of Oracle Corporation, Redwood City, California.

UNIX® is a registered trademark of The Open Group.

All other brand or product names are or may be trademarks or service marks, and are used to identify products or services, of their respective owners.

iStor Networks, Inc.  
7585 Irvine Center Drive  
Suite 250  
Irvine, CA 92618

## Safety Information

This product uses a lithium coin cell battery. The lithium coin cell battery is a long-life battery, and it is very possible that you will never need to replace it. However, should you need to replace it, consult your service documentation.



---

There is a danger of a new battery exploding if it is incorrectly installed. Replace the battery pack only with the same or equivalent type recommended by the manufacturer. Do not dispose of the battery along with household waste. Contact your local waste disposal agency for the address of the nearest battery deposit site.

---

### CAUTION:

RISK OF EXPLOSION IF BATTERY IS REPLACED BY AN INCORRECT TYPE. DISPOSE OF USED BATTERIES ACCORDING TO THE INSTRUCTIONS.

The iS512-10G product requires usage of laser transceivers (SFPs) to be installed. Such installation of any installed SFP must comply with the following:

1. The SFP to be installed must be UL Recognized as I.T.E.
2. The Laser Class of the SFP to be installed must be Class 1.
3. The transceivers of the SFP to be installed must comply with U.S. Code of Federal Regulations, 21 CFR 1040.
4. Those transceivers of the SFP to be installed must conform to the applicable requirements of 21 CFR Subchapter J.

## Notice of Export Controls

Export of technical data contained in this document may require an export license from the United States government. Please contact iStor Networks, Inc. for any export compliance questions.

## Document Revision Level

Revision	Date	Description
iS512HWRF1P00	July 2008	Version 1.0: initial release
iS512HWRF1P10	September 2008	Version 1.1: updated for software version 2.5.0 and redundant controllers
iS512HWRF1P20	January 2009	Version 1.2: minor formatting updates and clarification of network connections when using dual controllers
iS512HWRF1P30	May 2009	Version 1.3: updated for 84 drive support and version 2.6.0 software
iS512HWRF1P40	January 2010	Version 1.4: added iS512-04 and other minor updates
iS512HWRF1P50	November 2010	Version 1.5: added information about REBIND with redundant controllers with the version 2.8.0 software release, and other minor formatting updates

# Preface

This document is intended to assist users with installing the primary array and expansion array of the iS512 storage system from iStor Networks. This document assumes that users are computer literate, familiar with Storage Array Products, and have a basic understanding of storage products and concepts. Throughout this document, the term “iS512” refers to all of the members of the iS512 family, whereas a reference to a specific model will appear as iS512-04, iS512-08 or iS512-10G.

## Typographic Conventions

### Notes

Notes provide information that deserves special attention. They are preceded by:



### Cautions

Cautions contain information which, if not followed, can cause damage to the storage system and possible loss of data. They are preceded by:



### Warnings

Warnings contain information which, if not followed, can cause damage to the storage system and to the person installing it. They are preceded by:



## Related Documentation

In addition to this document, the following documents are available from iStor Networks.

- *iStor iS512 Quick Start Guide* (document number iS512QS). This guide provides the information needed to get the iS512 primary array out of the box and operational with a direct connection to a host computer.
- *iStor iS512-SX Expansion Array Quick Start Guide* (document number iS512SXQS). This guide is shipped with an iS512-SX expansion array and describes how to install and configure the expansion array for operation with the iS512 primary array.
- *Management Center Software User's Guide* (document number iMCSWUG). This guide provides information for configuring and managing storage on the iS512 storage system using the graphical user interface.
- *Command Line Interface User's Guide* (document number iSCLIUG). This guide provides the information needed to configure and manage storage on the iS512 storage system using the command line interface.
- *iStor Virtual Disk Services Guide* (document number D000045) describes how to use Microsoft Virtual Disk Services (VDS) to manage the iS512 storage systems.
- *iStor Terminology Guide* (document number iSTG). This guide is designed to assist you in the understanding of storage and SAN terminology that may be used in relation to the iS512 storage system. You may want to print this guide while reviewing the information and concepts in this document.

## Contact Information

For more information about the iS512-series storage systems or iStor Networks, Inc., please contact us using any of the following methods:

- **Voice calls:** (949) 753-8999.
- **Email:** If you prefer, you can send information requests to our e-mail address: [info@istor.com](mailto:info@istor.com).
- **Fax calls:** You can also send your requests for information to our 24-hour fax number: (949) 753-1068.
- **Web site:** Our Web site contains valuable information about our products. We encourage you to visit us at <http://www.istor.com>.
- **Technical support:** The customer-satisfaction arm of iStor Networks is available by calling (800) 689-1409 or through email at [support@istor.com](mailto:support@istor.com).

This Page Left Intentionally Blank

# Contents

<b>Chapter 1</b>	<b>Introduction.....</b>	<b>1</b>
1.1	Models.....	2
1.2	Features and Benefits.....	3
1.3	System Overview .....	4
<b>Chapter 2</b>	<b>iS512 Primary Array Layout.....</b>	<b>5</b>
2.1	Front Panel Components .....	6
2.2	Rear Panel Components .....	8
2.3	Side, Top and Bottom Panel Components .....	11
<b>Chapter 3</b>	<b>Installing the iS512 Primary Array .....</b>	<b>13</b>
3.1	Site Considerations.....	14
3.1.1	General Considerations .....	14
3.1.2	Desktop or Shelf Installation .....	14
3.1.3	Rack-mount Guidelines.....	15
3.2	Safety Considerations.....	15
3.3	Unpacking the iS512 Primary Array.....	16
3.4	Items Supplied by the User .....	16
3.5	Connecting to the iSCSI Data Ports .....	16
3.5.1	iS512-04 and iS512-08 Data Ports.....	17
3.5.2	iS512-10G Data Port .....	17
3.6	Connecting to the Management Port .....	17
3.7	Connecting the Power Cords.....	19
3.8	Powering-on the iS512 Primary Array .....	20
<b>Chapter 4</b>	<b>iS512-SX Expansion Array Layout and Installation.....</b>	<b>21</b>
4.1	Expansion Array Front Panel Components .....	22
4.2	Expansion Array Rear Panel Components .....	24
4.3	Site, Safety, and Rack-Mount Considerations .....	24
4.4	Unpacking the iS512-SX Expansion Array .....	24
4.5	Items Supplied by the User .....	25
4.6	Installing the iS512-SX Expansion Array.....	25
4.7	Connecting to the iS512-SX Expansion Arrays to iS512-08 or iS512-10G .....	26
4.8	Connecting to the iS512-SX Expansion Arrays to iS512-04 .....	27
4.9	Connecting the AC Power Cords.....	28
4.10	Powering-on the iS512-SX Expansion Array .....	28
<b>Appendix A</b>	<b>Replacing and Upgrading FRUs.....</b>	<b>29</b>
A.1	Installing or Replacing Drives.....	30
A.2	Replacing a Power Supply Module in the Primary or Expansion Array .....	31
A.3	Replacing the Controller Module on the Primary Array .....	32
A.4	Replacing the I/O Module on the Expansion Array .....	33
A.5	Connecting to the Diagnostic Serial Port .....	34
<b>Appendix B</b>	<b>Installing the System in a Rack.....</b>	<b>37</b>
<b>Index</b>	<b>.....</b>	<b>41</b>

## List of Figures

Figure 1-1. Example of an iS512 Storage System Configuration .....	4
Figure 2-1. Front View of the iS512 Primary Array.....	6
Figure 2-2. Close-up View of the Lever Release Button and Status LEDs on a Drive Carrier ...	6
Figure 2-3. Drive Numbers on the Primary Array.....	6
Figure 2-4. Rear View of the iS512 Primary Array (iS512-08 shown) .....	8
Figure 2-5. Close-up View of iS512-08 Controller Rear Panel .....	9
Figure 2-6. Close-up View of iS512-04 Controller Rear Panel .....	9
Figure 2-7. Rear View of the iS512-10G Primary Array.....	9
Figure 2-8. Close-up View of iS512-10G Controller Rear Panel .....	9
Figure 3-1. Connecting Data and Management Ports (iS512 Single Controller).....	18
Figure 3-2. Connecting Data and Management Ports (iS512-10G Single Controller) .....	18
Figure 3-3. Connecting Data and Management Ports (iS512-08 Dual Controllers shown) .....	19
Figure 4-1. Front View of the iS512 Expansion Array .....	22
Figure 4-2. Close-up View of the Lever Release Button and Status LEDs on a Drive Carrier ..	23
Figure 4-3. Drive Numbers on the Primary and Expansion Arrays (iS512-08 and iS512-10G) ..	23
Figure 4-4. iS512-SX Rear View (shown with dual I/O Modules) .....	24
Figure 4-5. Connecting the iS512-SX Expansion Arrays to the iS512 Primary Array.....	26
Figure 4-6. Connecting the iS512-SX Expansion Arrays to the iS512-04 Primary Array .....	27
Figure A-1. Installing a Drive .....	30
Figure A-2. Securing a Drive in the Slot .....	30
Figure A-3. Removing a Power Supply and Fan Module (right-most module shown).....	31
Figure A-4. Removing the Controller Canister on the Primary Array (Slot #0 shown) .....	32
Figure A-5. Removing the I/O Module on the Expansion Array (Slot #0 shown) .....	33
Figure A-6. Diagnostic Serial Port on Array Rear Panel .....	34
Figure B-1. Example of Mounting Hole Locations on the Front and Rear Rack Rails.....	37
Figure B-2. Securing the Main and Rear Rails.....	38
Figure B-3. Securing the Rails to the Rack .....	39
Figure B-4. Sliding the Array onto the Rails.....	39
Figure B-5. Securing the Array to the Rack .....	40

## List of Tables

Table 1-1. iS512 Primary Storage Array Models .....	2
Table 2-1. Enclosure LEDs.....	7
Table 2-2. Drive Carrier Status LEDs .....	7
Table 2-3. Failure Conditions that Activate the System Fault LED and Audio Alarm .....	7
Table 2-4. Management and Data Port Speed and Activity LEDs (iS512-04 and iS512-08) .....	10
Table 2-5. Data Port Speed and Activity LEDs (iS512-10G) .....	10
Table 2-6. Rear Panel Switches .....	10
Table 2-7. Rear Panel LEDs (iS512 and iS512-10G).....	11
Table 3-1. User-Supplied Items for Installing the iS512 Primary Array .....	16
Table 4-1. Enclosure LEDs.....	22
Table 4-2. Drive Carrier Status LEDs .....	23
Table 4-3. User-Supplied Items for Installing the iS512-SX Expansion Array.....	25

# Chapter 1 Introduction

The iStor iS512 storage system is an intelligent, high-performance multiple Gigabit Ethernet storage solution designed for businesses that want to improve the reliability, availability, serviceability, and performance of their storage systems. It provides a range of benefits and features from its ability to use familiar, proven, and widespread networking technologies like IP and Ethernet for storage solutions.

The iS512 storage system is highly scalable. To add more storage capacity, simply connect up to six additional expansion arrays to the iS512-08 or iS512-10G primary array for up to 84 drives, or up to three additional expansion arrays to the iS512-04 for up to 48 drives. This plug-and-play approach to storage expansion enables you to form a scalable enterprise storage grid of many drives quickly and easily.

Based on an Internet Protocol-Storage Area Network (IP-SAN) architecture, the iS512 primary array is built around iStor's iSCSI RAID processor System-On-A-Chip and has the following features:

- Up to 12 internal Serial Attached SCSI (SAS) or Serial Advanced Technical Attachment (SATA) drives per chassis, for a total of up to 84 drives per system (when additional iS512-SX expansion arrays are connected)
- Support for redundant controllers for High Availability
- Up to 4 GB of system memory
- Up to 4 GB of buffer memory
- iSCSI Ethernet Connectors:
  - Four 1-Gigabit RJ-45 connectors for the iS512-04;
  - Eight 1-Gigabit RJ-45 connectors for the iS512-08;
  - One 10-Gigabit optical connector for the iS512-10G
- A 10/100/1000 Mbps Ethernet management port
- Two expansion connectors for attaching up to six additional expansion arrays
- A 115.2 Kbps RS-232-C stereo mini-jack diagnostic port for troubleshooting purposes

Complete configuration and management of the storage system are available through the intuitive, graphical-based Management Center software.



---

For the latest information about supported drives, consult the inAble<sup>™</sup> matrix on the iStor Web site: [www.iStor.com](http://www.iStor.com).

---

## 1.1 Models

The iS512 Primary Storage array is available in various models. The models differ according to the speed and host network interface. Table 1-1 lists the iS512 Primary Array models.

Table 1-1. iS512 Primary Storage Array Models

Model	Description
iS512-08	Number of host network connections: Eight RJ-45 ports Speed: 1 Gbps Maximum number of internal SATA or SAS drives: 12 Maximum number of total SATA or SAS drives (with iS512-SX Expansion Arrays): 84 Maximum amount of system memory: 4 GB Maximum amount of buffer memory: 4 GB Single or Dual controllers
iS512-04	Number of host network connections: Four RJ-45 ports Speed: 1 Gbps Maximum number of internal SATA or SAS drives: 12 Maximum number of total SATA or SAS drives (with iS512-SX Expansion Arrays): 48 Maximum amount of system memory: 4 GB Maximum amount of buffer memory: 4 GB Single or Dual controllers
iS512-10G	Number of host network connections: One optical XFP transceiver host network connection Speed: 10 Gbps Maximum number of internal SATA or SAS drives: 12 Maximum number of total SATA or SAS drives (with iS512-SX Expansion Arrays): 84 Maximum amount of system memory: 4 GB Maximum amount of buffer memory: 4 GB Single or Dual controllers

## 1.2 Features and Benefits

- High-performance, low-latency iSCSI storage system, with a highly integrated multifunction ASIC for fully featured, integrated storage virtualization
- High Availability with automatic failover and failback (also known as “rebind”) when configured with dual controllers
- Modular design with the ability to add up to six hot-swappable 12-drive expansion arrays for up to 84 drives for iS512-08 and iS512-10G systems, or up to 48 drives for iS512-04 systems.
- Easy setup and configuration - can be installed anywhere on a Gigabit or 10-Gigabit Ethernet network for improved access to critical information
- In-band or out-of-band management via direct connection or the Web
- Delivers Ethernet economics to storage for lower total cost of ownership and rapid deployment using known and trusted technologies
- Proven transport infrastructure for increased reliability, investment protection, and reduced training and administrative costs
- Scalability over long distances - ideal for remote data replication and disaster recovery
- High availability - redundant fans and 2 redundant, hot-swappable, auto-sensing, load-sharing power supplies
- Intelligent battery pack ensures that a charged battery is on hand to preserve buffer cache contents if a power failure occurs. Contents are backed up for approximately 72 hours with the standard 2GB data cache (48 hours with the 4GB data cache option).

## 1.3 System Overview

Figure 1-1 shows a typical iS512 storage system configuration in a Storage Area Network (SAN). The SAN shown is an Ethernet network used solely for exchanging data between the customer's host servers and the iS512 storage system. The Ethernet bandwidth used by the servers exchanging data with the iS512 storage system can be very high. Using a separate Ethernet to act as a SAN keeps that data from interfering with the customer's existing LAN and improves security.

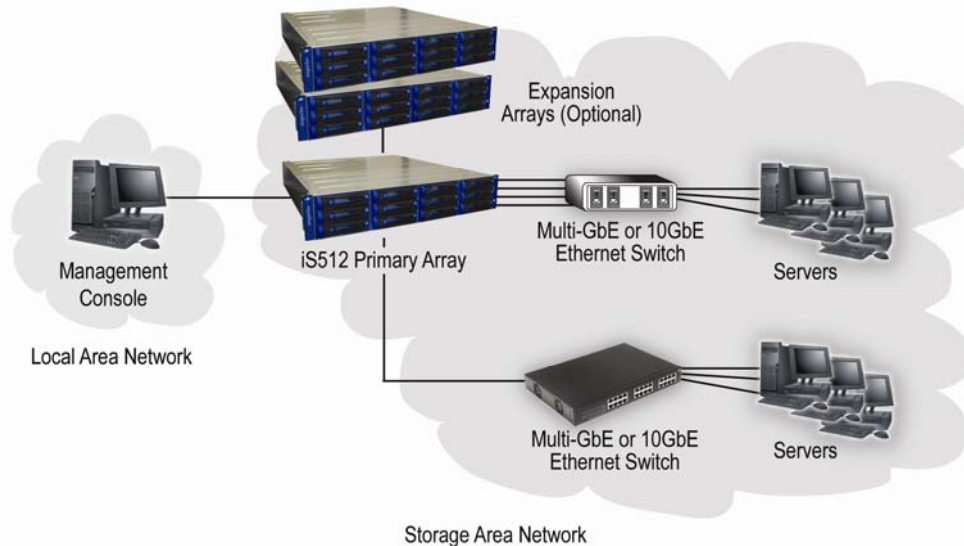

Figure 1-1. Example of an iS512 Storage System Configuration

When equipped with dual controllers, the iS512 system provides High Availability with automatic failover to the surviving controller. When a failure occurs on the primary controller, the Management Port and all of the iSCSI data ports are automatically redirected to the equivalent ports on the redundant controller, without any interruption to your host server applications. To accomplish the redirection of network traffic on those ports, a network switch **must** be used between the host server(s) and both of the iS512 controllers prior to system startup to allow the automatic re-direction of the network connections to the redundant controller when a failure occurs on the primary controller. For example, the Management Port network connection on both controllers must be connected to the same network switch. Similarly, Data Port 0 on both controllers must also be connected to the same network switch, and so on.

The physical configuration of the two controllers must be the same before they can operate as a redundant pair, including the type and number of iSCSI data ports, System and Buffer memory sizes, and embedded software version.

If a controller failure occurs as a result of an unexpected software problem, the failed controller will automatically restart and the system will return to a fully redundant state. If the controller failure occurs as a result of a hardware failure, the failed controller will be held in a non-functional state until it can be replaced with a working controller. When the replacement controller is installed, it will automatically re-bind with the surviving controller, thereby returning the system to a fully redundant state.

A Field Upgrade Kit is available to add a redundant controller to any existing single-controller iS512 system. Similarly, a Field Upgrade Kit is available to add a second I/O Module to the iS512-SX Expansion Array, which is required when the iS512 Primary Array is equipped with dual controllers.

## Chapter 2 iS512 Primary Array Layout

This chapter describes the hardware components on the iS512 primary array. The topics covered in this chapter are:

- Section 2.1, Front Panel Components (page 6)
- Section 2.2, Rear Panel Components (page 8)
- Section 2.3, Side, Top and Bottom Panel Components (page 11)

## 2.1 Front Panel Components

The front of the iS512 primary array enclosure has the following components (see Figure 2-1):

- Enclosure LEDs - four enclosure LEDs at the right side of the front panel provide status information about the iS512 primary array enclosure. For a description of these LEDs, see Table 2-1.
- Drive slots - the front panel provides access to 12 drive slots. The drive slots are arranged in four columns of 3 slots.
- Drive carriers - drives are mounted on a drive carrier. Drive carriers have a push-button lever for installing and removing drives, and three status LEDs (see Figure 2-2 and Table 2-2). Each carrier has a corresponding drive slot number (see Figure 2-3). Filler panels must be installed in all drive slots that are not occupied by a drive.

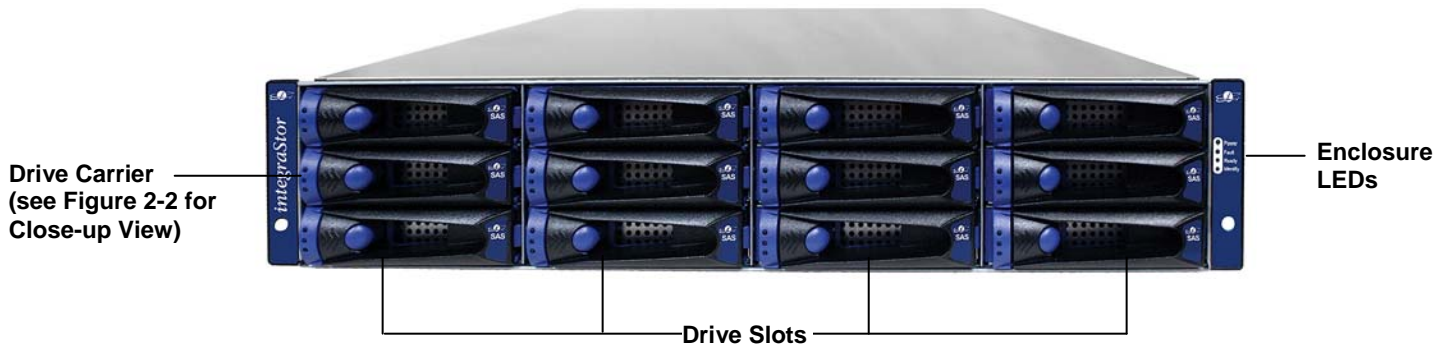

Figure 2-1. Front View of the iS512 Primary Array

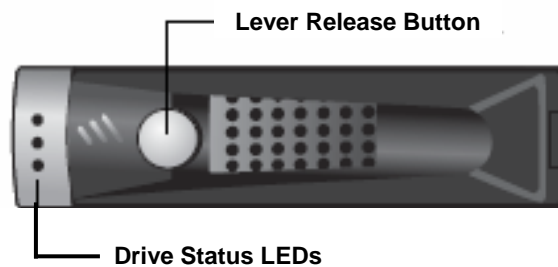

Figure 2-2. Close-up View of the Lever Release Button and Status LEDs on a Drive Carrier



Figure 2-3. Drive Numbers on the Primary Array

Table 2-1. Enclosure LEDs

LED	Color	Description
Power	Green	ON: primary array is powered on.
		OFF: power is not being received.
Fault	Amber	ON: a fault occurred with the power supply, fan, over temperature, internal module, or controllers. Refer to Table 2-3 for information about possible causes.
		OFF: normal operation.
Ready	Green	ON: normal operation.
		OFF: normal while iS512 primary array is booting. After initialization, this status indicates a problem with the iS512 primary array.
Identify	Blue	Flash: used to visually identify the enclosure.
		OFF: no identification is being performed.

Table 2-2. Drive Carrier Status LEDs

	LED	Color	Description
	LED 1	Green	This LED is reserved for future use.
	LED 2	Green	OFF: no drive is installed (drive slot is empty).
			ON: drive is online, ready for operation.
			Slow Flash: drive is being prepared for removal or is being rebuilt.
			Fast Flash: drive is being identified (future capability)
		Amber	Fast Flash: drive failed and should be replaced (see Appendix A for information about installing or replacing drives)
	LED3	Green	Flash: drive activity is occurring.

Table 2-3. Failure Conditions that Activate the System Fault LED and Audio Alarm

Failure Condition	Description and Additional Information
Power Supply Failure	The System Fault LED will be illuminated and the audible alarm will sound.
Cooling Fan Failure	The System Fault LED will be illuminated and the audible alarm will sound.
Battery Failure	The System Fault LED will be illuminated and the audible alarm will sound. A system restart is required after the battery has been replaced.
Over Temperature	The System Fault LED will be illuminated and the audible alarm will sound.
Software Failure	The System Fault LED will be illuminated and the audible alarm will sound.

## 2.2 Rear Panel Components

The rear panel of the iS512 primary array controller has the following components (see Figure 2-4 and Figure 2-5):

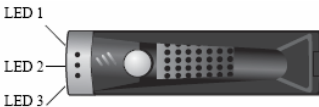
- Four or eight 1-Gigabit RJ-45 iSCSI data ports, one 10-Gigabit XFP iSCSI data port, or two 10-Gigabit RJ-45 iSCSI data ports are located on the rear panel of the iS512 chassis. Each iSCSI data port has port speed and port activity LEDs (see Table 2-4 for the iS512-04 and iS512-08, and Table 2-5 for the iS512-10G).
- Management port (MGMT) - one 10/100/1000 RJ-45 management is located to the right of the iSCSI data ports. The management port has port speed and port activity LEDs (see Table 2-4).
- Diagnostic port (DIAG) - one 115.2 Kbps RS-232-C diagnostic port (stereo mini-jack) is located above the top-right corner of the management port. To connect to this port, use the diagnostic cable supplied with your iS512-series system.
- Expansion ports (EXPO and EXP1) - two expansion ports are located to the right of the management port. These connectors allow you to attach up to six iS512-SX expansion arrays to the primary array to increase the array's storage capacity (see Section 4.7 for more information).
- Reset switch and restart switch - are located above the expansion ports. For an explanation of these switches, see Table 2-6.
- Ready/fault, battery status and A/B LEDs - are located above the expansion ports (see Table 2-7).

The rear panel of the iS512 primary array enclosure has two AC power receptacles and power switches. For an explanation of the power receptacles and power switches, see Sections 3.7 and 3.8. The **Mute Audio Alarm** button is located on the module that is located between the two AC power supply modules.

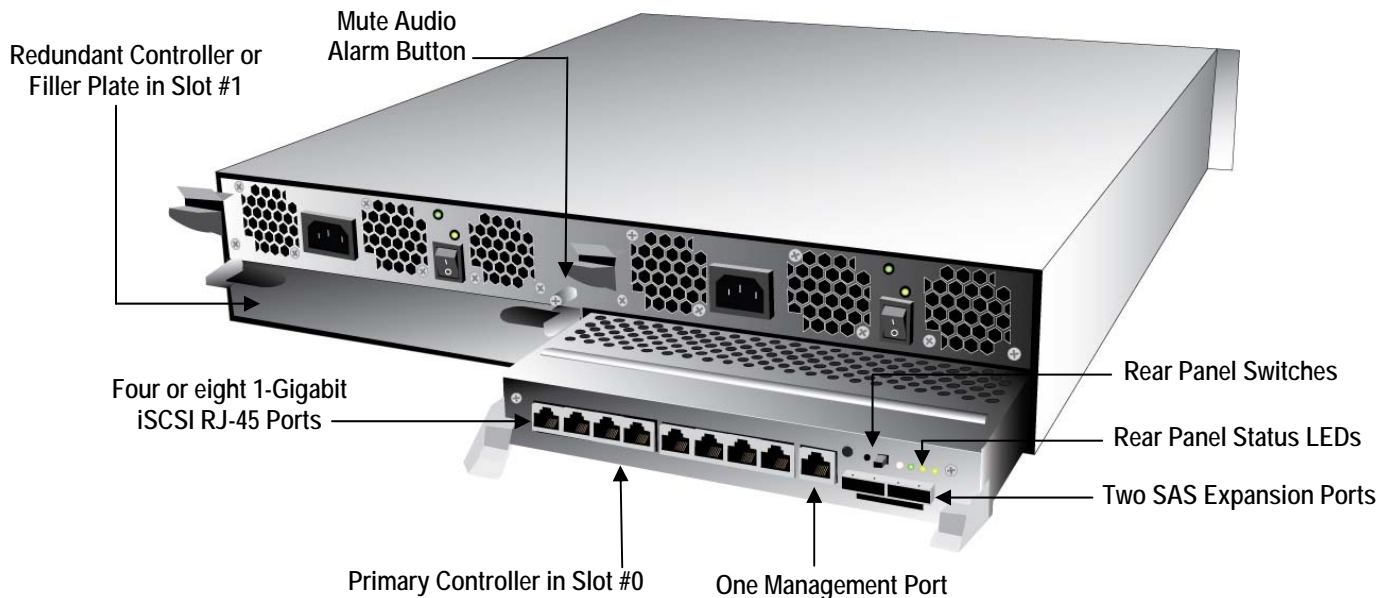

Figure 2-4. Rear View of the iS512 Primary Array (iS512-08 shown)

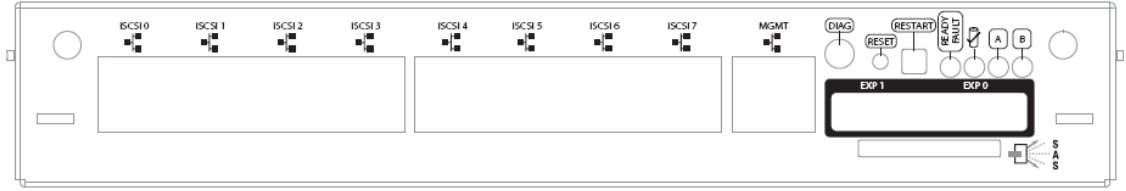

Figure 2-5. Close-up View of iS512-08 Controller Rear Panel



Figure 2-6. Close-up View of iS512-04 Controller Rear Panel

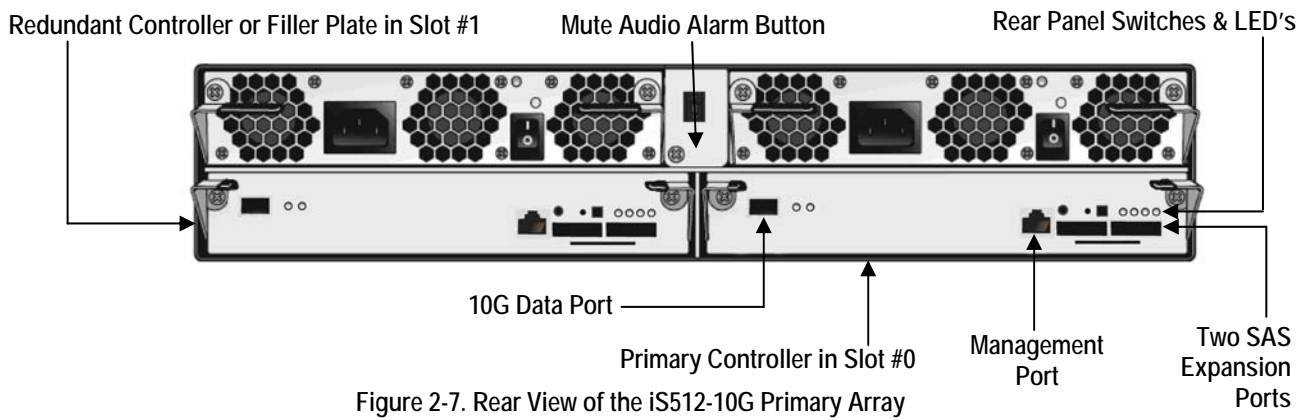

Figure 2-7. Rear View of the iS512-10G Primary Array

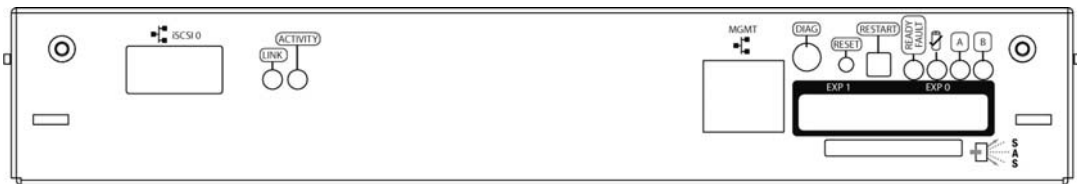

Figure 2-8. Close-up View of iS512-10G Controller Rear Panel



The iS512 primary array can be equipped with dual controllers for automatic failover in the event of a hardware or software failure on the primary controller. For systems with dual controllers, both controllers must have the same number and type of data ports.

To allow the automatic re-direction of the network connections to the redundant controller when a failure occurs on the primary controller, the network cables for the Management Port and each of the Data Ports must be connected to both controllers before the system starts up.

The network connections for the Management Port and each of the Data Ports must be connected to the same network switch to allow the failover mechanism to function correctly. For example, the Management Port of both controllers must be connected to the same switch, and Data Port 0 on both controllers must be connected to the same switch, although that switch can be different than the one used for the Management Port. The same method should be used for all other data ports.

**Table 2-4. Management and Data Port Speed and Activity LEDs (iS512-04 and iS512-08)**

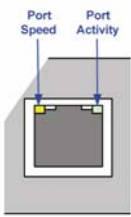
	LED	Color	Description
	Port Speed	Yellow	ON: link is operating at 1 Gbps.
			OFF: link is operating at either 10 Mbps or 100 Mbps.
	Port Activity	Green or Yellow	ON: link is operational.
Flash: data is being sent or received.			

**Table 2-5. Data Port Speed and Activity LEDs (iS512-10G)**

	LED	Color	Description
	Port Speed	Yellow	ON: link is operating at 10 Gbps
			OFF: link is not operating
	Port Activity	Green	ON: link is operational
Flash: data is being sent or received			

**Table 2-6. Rear Panel Switches**

Switch / LED	Description
Power	Applies power to the iS512 primary array. The iS512 primary array has two power switches. Both must be turned on.
Reset	Resets the system. This switch is recessed to prevent against accidental resets.
Restart	This switch is reserved for future use.

Table 2-7. Rear Panel LEDs (iS512 and iS512-10G)

Switch / LED	Color	Description
Ready/Fault	OFF	Primary array is powered off or performing its Power On Self Test.
	Red	A fault has occurred. Please contact iStor Networks Technical Support.
	Green	Normal operation.
	OFF	Battery is fully charged and not sustaining cache.
	Green	Solid: Battery is good or being charged.
		Flashing: Contents of system cache memory is being preserved by the battery subsystem after an unexpected loss of power or system failure has occurred.
"A" and "B" LEDs	Yellow	These LEDs are reserved for future use.

### 2.3 Side, Top and Bottom Panel Components

The left and right sides of the iS512 primary array enclosure do not require any special hardware for rack-mounting the unit - instead the enclosure simply slides into the rails that are supplied with the product.

Product information labels will be found on the top surface of the unit. For rack-mount instructions, refer to Appendix B and the documentation for your rack.

This Page Left Intentionally Blank

## Chapter 3 Installing the iS512 Primary Array

This chapter describes how to install the iS512 primary array. The topics covered in this chapter are:

- Section 3.1, Site Considerations (page 14)
- Section 3.2, Safety Considerations (page 15)
- Section 3.3, Unpacking the iS512 Primary Array (page 16)
- Section 3.4, Items Supplied by the User (page 16)
- Section 3.5, Connecting to the iSCSI Data Ports (page 16)
- Section 3.6, Connecting to the Management Port (page 17)
- Section 3.7, Connecting the Power Cords (page 19)
- Section 3.8, Powering-on the iS512 Primary Array (page 20)

## 3.1 Site Considerations

The site where you install the iS512 primary array can affect its performance. Therefore, choose a site that conforms to the requirements in the following sections.

### 3.1.1 General Considerations

Observe the following considerations when selecting a location to install the iS512 primary array.

- The location should be fairly cool and dry for the acceptable temperature and humidity ranges.
- The location should be free of strong electromagnetic field generators (such as motors), vibration, dust, and direct exposure to sunlight.
- The location must provide sufficient airflow to the front and back of the iS512 primary array for correct cooling. Ventilation must be sufficient to exhaust heat from the rear of the equipment.
- The location should offer a power outlet within six feet (1.82 meters) of the iS512 primary array.
- The location should allow for at least six inches (152.3 mm) of space at the front and back of the iS512 primary array for ventilation.
- Do not place the iS512 primary array next to, on top of, or below any device that generates a significant amount of heat or will block the free flow of air through the iS512 primary array ventilation slots.

### 3.1.2 Desktop or Shelf Installation

The iS512 primary array can be mounted on a desktop or shelf. Observe the following considerations for desktop or shelf installations.

- Select a sturdy, level surface that can support the iS512 primary array. A fully populated unit weighs approximately 85 pounds (38.6 kg).
- Allow enough ventilation space between the iS512 primary array and any other objects in the vicinity.
- Be sure not to block the air vents on the front and back of the iS512 primary array enclosure. Install the cables and power cords according to the procedures in the following sections.

### 3.1.3 Rack-mount Guidelines

The iS512 primary array can be mounted in a standard 19-inch rack. Observe the following considerations for rack installations. For information about installing the system in a rack, refer to Appendix B and to the documentation for the rack.

- All rack-mounting hardware must be carefully assembled to properly support the equipment. Follow the instructions in the documentation for the rack.
- The operating ambient temperature of rack-mounted equipment must not exceed the maximum rated ambient temperature indicated in this guide.
- The rack cabinet must provide sufficient airflow to the front and back of the iS512 primary array to maintain correct cooling. It must include ventilation sufficient to exhaust the heat generated by equipment installed in the rack.
- The rack must allow enough ventilation space between the iS512 primary array and any other objects in the vicinity. Do not block the air vents on the front and back of the iS512 primary array enclosure. The air flow clearances specified in this guide must be maintained within the rack.
- The AC supply circuit for rack-mounted equipment must be capable of supplying the total current specified on all the labels of the rack-mounted equipment.
- All AC power supply connections must be properly grounded. To ensure the integrity of the earth connection, special attention must be given to connections that are not directly connected to the branch circuit (for example, power strips).
- If additional iS512 expansion arrays will be added, leave sufficient space in the rack for those arrays, since the cables supplied for connections between the iS512 primary array and expansion arrays or between additional expansion arrays require that all arrays be in close proximity to each other.

## 3.2 Safety Considerations

Observe the following guidelines to ensure safety:

- Do not wear loose clothing that could get caught in the chassis mounting hardware.
- Wear safety glasses when working under conditions that are hazardous to your eyes.
- Do not perform any action that creates a potential hazard to people or makes the rack or equipment unsafe.
- Do not work on the equipment or disconnect cables during a thunderstorm, when wearing a wool sweater or other heavy wool clothing, or when power is applied.
- Disconnect all power before installation and before connecting or disconnecting cables.
- Avoid hazards such as moist floor and ungrounded power-extension cables.
- To avoid damage to the iS512 primary array due to Electrostatic discharge (ESD), wear an ESD-preventive wrist strap when working on the array. Connect the clip to an unpainted surface of the chassis frame to safely channel unwanted ESD voltages to ground. If no wrist strap is available, ground yourself by touching the metal part of the chassis.

### 3.3 Unpacking the iS512 Primary Array

After receiving the iS512 primary array, perform the following steps to ensure that the primary array and other contents arrived safely.

1. Inspect the outer shipping container for any damage that may have occurred in shipping. Report any sign of damage to the appropriate shipping agency.
2. Remove the iS512 primary array and cables from the shipping container.
3. Save the shipping container, foam, and antistatic bags in case you have to return the iS512 primary array. Returning the iS512 primary array in any other container is not advised.
4. Check the contents against the items referenced on the packing list. If any item is missing or damaged, notify a sales representative and/or the shipping agency.

### 3.4 Items Supplied by the User

Table 3-1 lists the additional items you must supply to install the iS512 primary array. All users must provide the items in the first row of Table 3-1. Rack-mount users must provide the additional items shown.

Table 3-1. User-Supplied Items for Installing the iS512 Primary Array

User Category	User-Supplied Items
All Users	<ul style="list-style-type: none"><li>▪ A PC with a Network Interface Card (NIC) that will act as the iSCSI initiator. (See Note 1)</li><li>▪ A PC with a NIC and Internet access that will access the management console. (See Note 1)</li><li>▪ Two available AC outlets not controlled by a wall switch.</li><li>▪ An IP address for each iS512 primary array host connection data port that will connect to your SAN.</li><li>▪ For the iS512, an Ethernet cable for each iS512 primary array host connection RJ-45 data port that will connect to your SAN (the iS512 primary array auto-senses the network link speed and type of cable used).</li><li>▪ For the iS512-10G, an XFP module for the type of 10 Gigabit network (LR, SR, CX4, etc.).</li><li>▪ An Ethernet switch and Ethernet cables are optional for Single Controller systems, but required for Dual Controller systems. If you want to use the iS512 primary array's Link Aggregation feature, the switch must support LAGs.</li></ul>
Rack-Mount Users	<ul style="list-style-type: none"><li>▪ A standard NEMA-compliant 19-inch rack.</li><li>▪ Additional mounting hardware for specific rack being used, if necessary.</li></ul>

Note 1: For convenience, one PC with three installed NICs can be used instead of separate PCs. In this configuration, one NIC connects to the iS512 primary array management port, a second NIC connects to the Internet, and a third NIC is used with the iSCSI initiator.

### 3.5 Connecting to the iSCSI Data Ports

The following sections describe how to connect the iS512 primary array data ports. If you have the iS512 array, follow the instructions in section 3.5.1. If you have the iS512-10G array, follow the instructions in section 3.5.2.

### 3.5.1 iS512-04 and iS512-08 Data Ports

The iS512 primary array has eight 1-Gigabit RJ-45 data ports labeled iSCSI 0 through iSCSI 7 (see Figure 2-4 on page 8 and Figure 2-5 on page 9). These ports connect to your SAN using either a straight-through or cross-over RJ-45 Ethernet cable (the iS512 primary array auto-senses the network link speed and type of cable used). One cable is needed for each RJ-45 data port.

1. Attach one end of an Ethernet cable to the data port labeled iSCSI 0 on the iS512 primary array back panel (see Figure 2-5 on page 9 and Figure 3-1). Connect the other end of the cable to your SAN or host system.
2. To connect additional host network connection ports to your SAN, repeat step 1 using another Ethernet cable and the next available iS512 primary array port in sequence (port iSCSI 1, then port iSCSI 2, and so on).

### 3.5.2 iS512-10G Data Port

The iS512-10G has one 10 Gigabit XFP iSCSI data port labeled iSCSI 0 (see Figure 2-7 and Figure 2-8 on page 9). This port connects to an XFP module for the appropriate 10 gigabit network (for example, LR, SR, or CX4).

1. Connect one end of a single mode or multimode XFP optical cable to the iS512-10G storage system optical host network connection port (see Figure 2-5 on page 9 and Figure 3-2).
2. Connect the other end of the cable to your SAN or host system.

## 3.6 Connecting to the Management Port

Connecting a PC to the management port lets you configure and manage the iS512 primary array. This connection is made using a PC with an installed NIC and either a cross-over cable (if connecting directly to a 10/100 management port) or a straight-through cable (if connecting to a Gigabit Ethernet management port, or using a hub or switch).

To receive email alerts from the iS512 primary array, be sure the management port can communicate via Ethernet with your mail server.

1. Connect either end of an Ethernet cable to a NIC installed in a PC.
2. Connect the other end of the cable into the iS512 primary array MGMT port (see Figure 2-5 on page 9, Figure 3-1, Figure 3-2, Figure 3-3 and Error! Reference source not found.).



Do not connect one NIC to the management and host network connection ports. Connect one NIC to the management port and connect another NIC in the same PC or a different PC to the host network connection port(s).

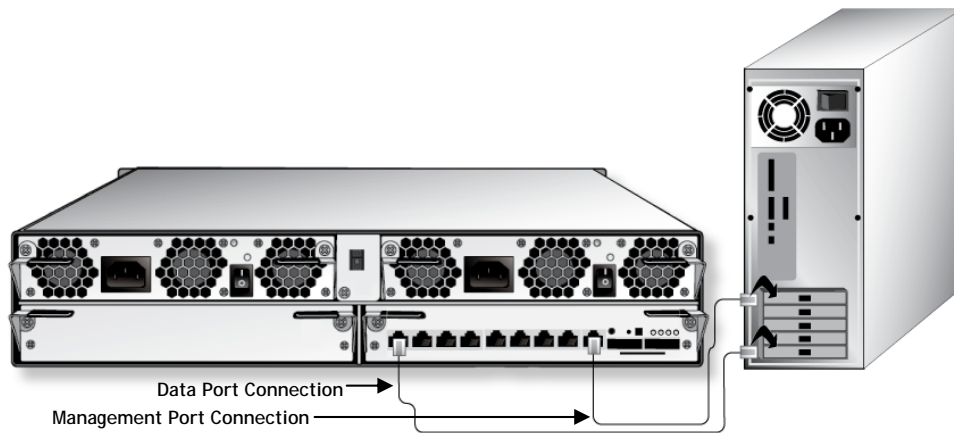

Figure 3-1. Connecting Data and Management Ports (iS512 Single Controller)

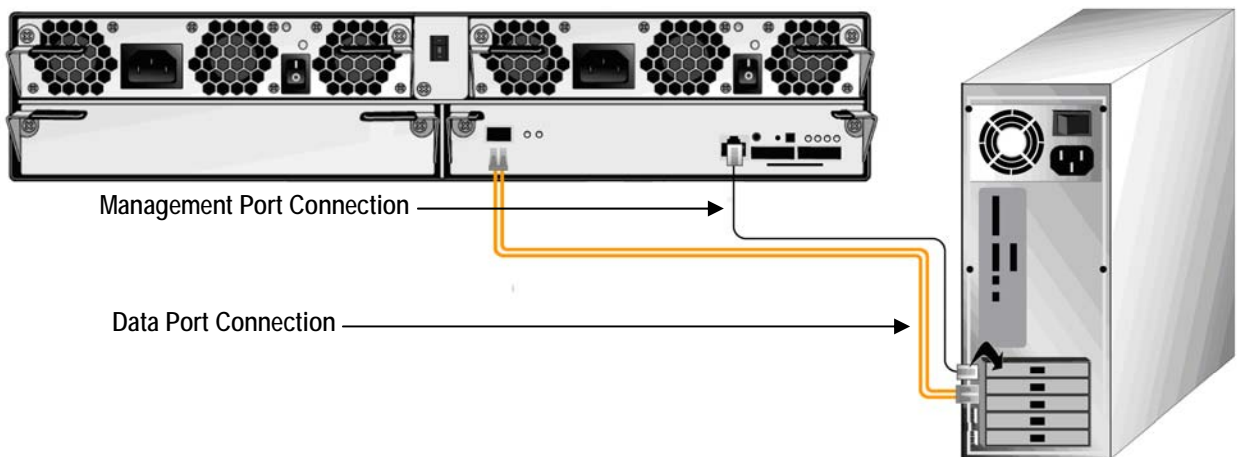

Figure 3-2. Connecting Data and Management Ports (iS512-10G Single Controller)

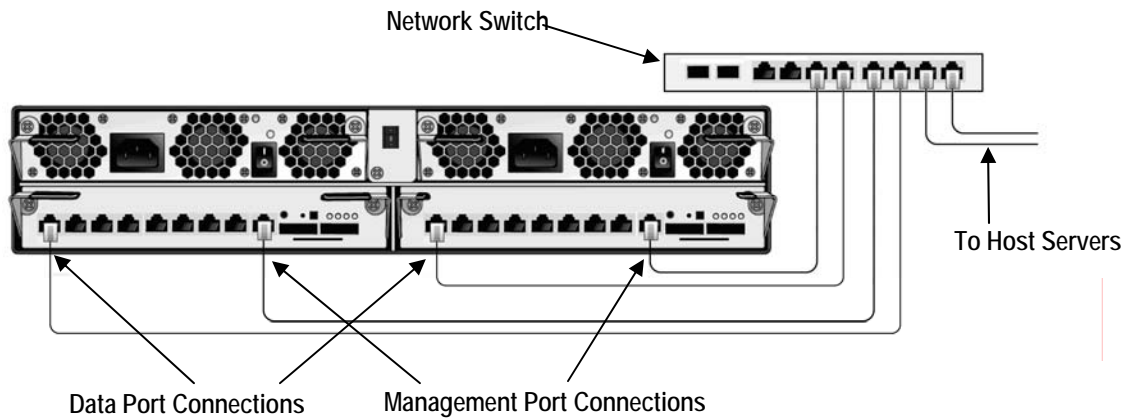
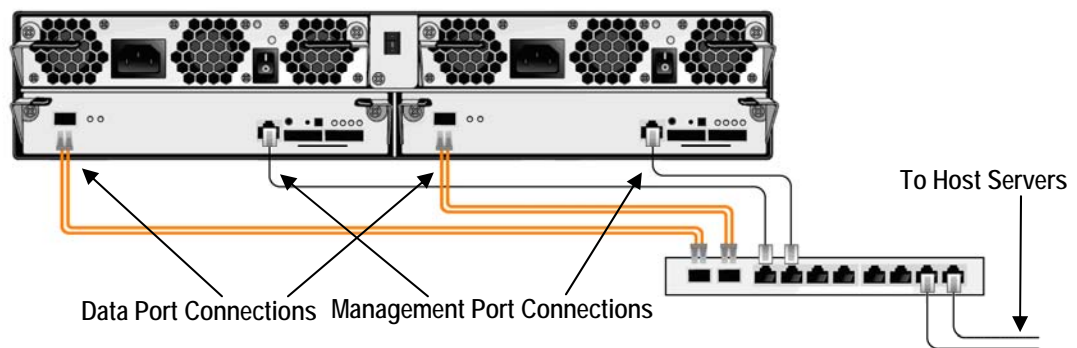

Figure 3-3. Connecting Data and Management Ports (iS512-08 Dual Controllers shown)



### 3.7 Connecting the Power Cords

The iS512 primary array has two power receptacles. Both must be used to connect the iS512 primary array to an AC outlet:

1. Plug the female end of one power cord into one of the 3-pronged power connectors on the back of the iS512 primary array. Plug the other end of the power cord into a working AC outlet that is not controlled by a wall switch.
2. Repeat the previous step using the second power cable and power receptacle on the iS512 primary array. For best results, the second power receptacle should be on a different circuit.



Although the iS512 primary array can operate temporarily with only one AC power connection, an audio alarm will sound until both power supply units are powered on.

### 3.8 Powering-on the iS512 Primary Array

To power-on the iS512 primary array, turn on both of the rocker switches on both power supplies at the rear of the unit. When the iS512 primary array powers-on, the following actions occur:

- The front panel **Power** LED turns green.
- The iS512 primary array runs its power-on procedure (up to 5 minutes), after which the **READY** LED on the right front bracket turns green.

After the iS512 primary array powers-on for the first time, it automatically loads the factory-default configuration settings. If necessary, you can use the Management Center software to change these settings to suit your requirements. For a description of the array's factory-default configuration settings and how to change them, refer to the Management Center User's Guide.

## Chapter 4 iS512-SX Expansion Array Layout and Installation

This chapter describes the hardware components and installation instructions for the iS512-SX Expansion Array. The topics covered in this chapter are:

- Section 4.1, Expansion Array Front Panel Components (page 22)
- Section 4.2, Expansion Array Rear Panel Components (page 24)
- Section 4.3, Site, Safety, and Rack-Mount Considerations (page 24)
- Section 4.4, Unpacking the iS512-SX Expansion Array (page 24)
- Section 4.5, Items Supplied by the User (page 25)
- Section 4.6, Installing the iS512-SX Expansion Array (page 25)
- Section 4.7, Connecting to the iS512-SX Expansion Array (page 26)
- Section 4.8, Connecting to the iS512-SX Expansion Arrays to iS512-04 (page 27)
- Section 4.9, Connecting the AC Power Cords (page 28)
- Section 4.10, Powering-on the iS512-SX Expansion Array (page 28)

## 4.1 Expansion Array Front Panel Components

The front of the iS512 expansion array enclosure has the following components (see Figure 4-1):

- LEDs - four enclosure LEDs at the right side of the front panel provide status information about the iS512 primary array enclosure. For a description of these LEDs, see Table 4-1.
- Drive slots - the front panel provides access to 12 drive slots. The drive slots are arranged in four columns of 3 slots.
- Drive carriers - drives are mounted on a drive carrier. Drive carriers have a push-button lever for installing and removing drives, and three status LEDs (see Figure 4-2 and Table 4-2). Each carrier has a corresponding drive slot number (see Figure 4-3). Filler panels must be installed in all drive slots that are not occupied by a drive.

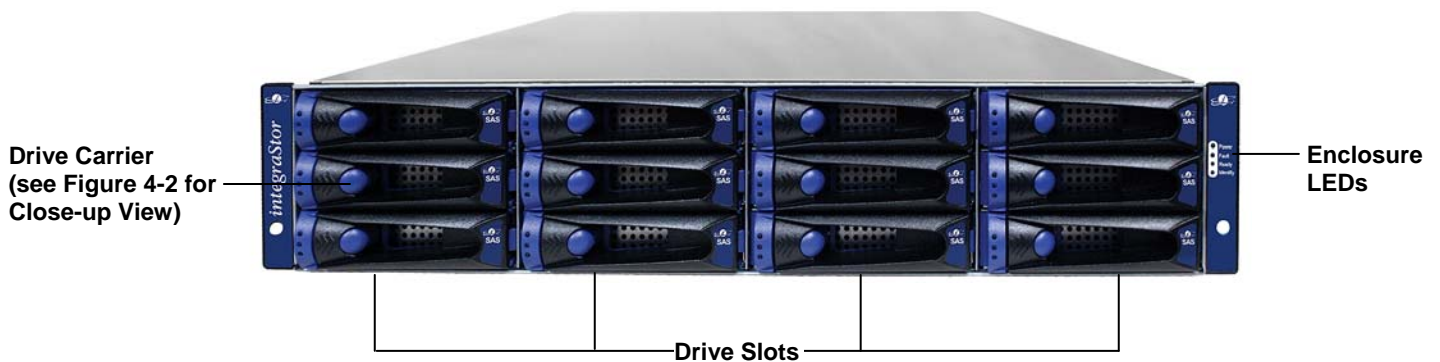

Figure 4-1. Front View of the iS512 Expansion Array

Table 4-1. Enclosure LEDs

LED	Color	Description
Power	Green	ON: expansion array is powered on.
		OFF: power is not being received.
Fault	Amber	ON: a fault occurred with the power supply, fan, over temperature, internal module, or controllers.
		OFF: normal operation.
Ready	Green	ON: normal operation.
		OFF: normal while iS512-SX expansion array is booting. After initialization, this status indicates a problem with the iS512-SX expansion array.
Identify	Blue	Flashing: expansion array is trying to identify the physical location of a drive using the iS512 Management Center software.
		OFF: no identification is being performed.

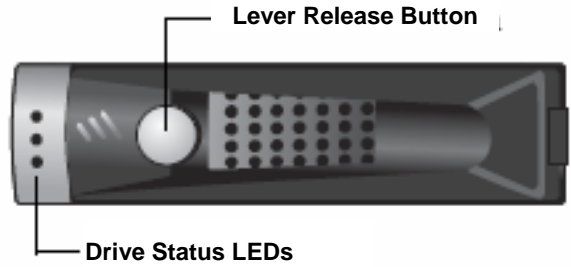

Figure 4-2. Close-up View of the Lever Release Button and Status LEDs on a Drive Carrier

Table 4-2. Drive Carrier Status LEDs

LED	Color	Description
LED 1	Green	This LED is reserved for future use.
LED 2	Green	OFF: no drive is installed (drive slot is empty).
		ON: drive is online, ready for operation.
		Slow Flash: drive is being prepared for removal or is being rebuilt.
		Fast Flash: drive is being identified.
	Amber	Fast Flash: drive failed and should be replaced (see Appendix A for information about installing or replacing drives)
LED3	Green	Flash: drive activity is occurring.

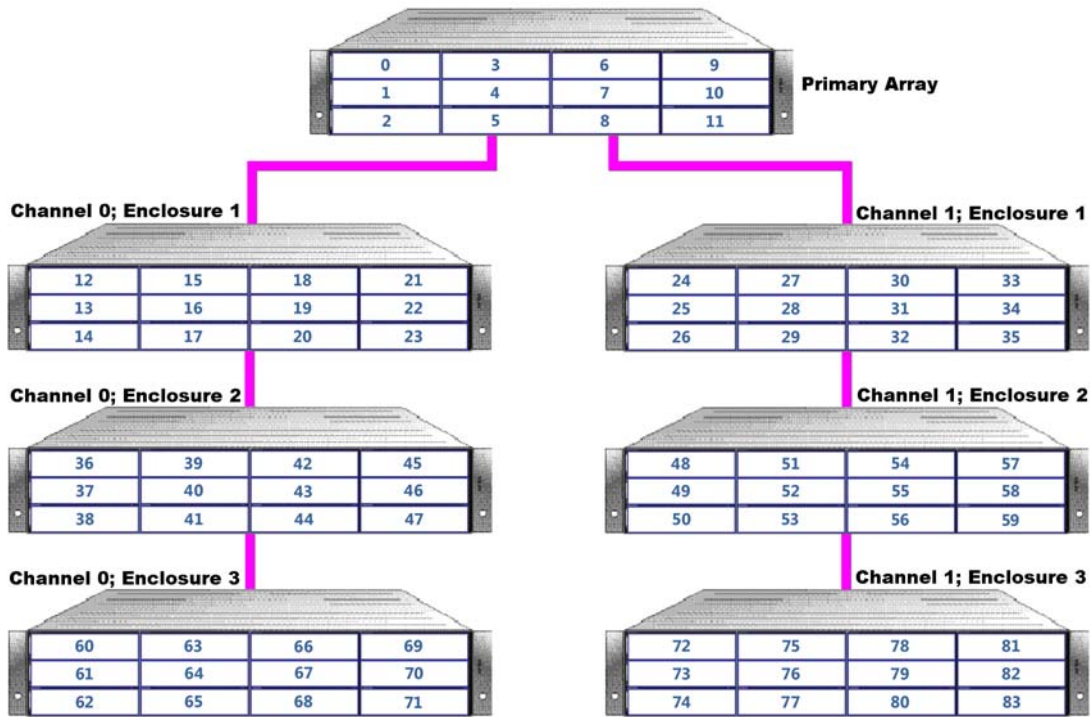



Figure 4-3. Drive Numbers on the Primary and Expansion Arrays (iS512-08 and iS512-10G)

## 4.2 Expansion Array Rear Panel Components

The rear of the i512-SX expansion array enclosure has the following components (see Figure 4-4):

- One or two I/O modules, each containing two SAS connectors (**HOST** and **EXP**); the **HOST** connector connects the expansion array to the mini-SAS connector on the back of the i512 primary array. The **EXP** connector is used to connect additional i512-SX expansion arrays using a SAS-to-SAS expansion cable (supplied separately).
- Power - two power receptacles and power switches are located on the left side of the rear panel. Both power switches must be turned on.

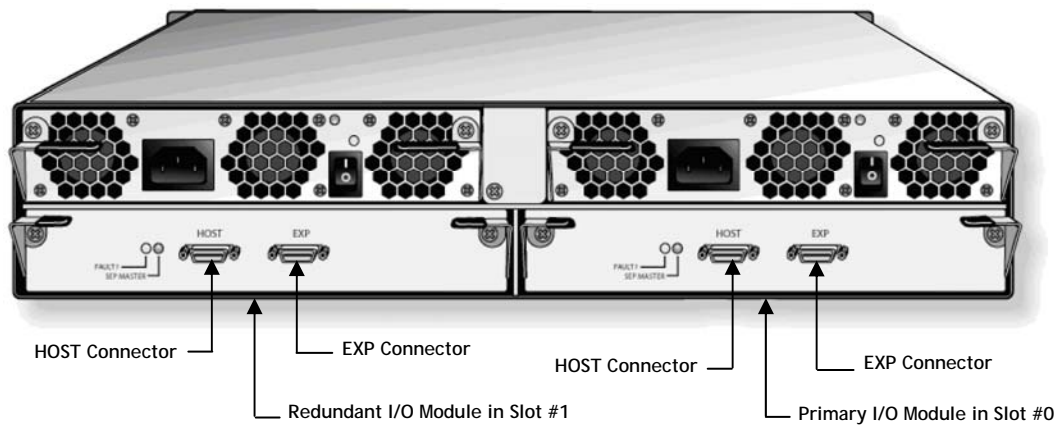

Figure 4-4. i512-SX Rear View (shown with dual I/O Modules)



The i512-SX expansion array can be equipped with either one or two I/O modules. The redundant I/O module is required in the Expansion Array when used with a Primary Array that is equipped with dual controllers.

## 4.3 Site, Safety, and Rack-Mount Considerations

All site, safety, and rack-mount considerations listed for the i512 primary array in section 3.1 also apply to the i512-SX expansion array.

## 4.4 Unpacking the i512-SX Expansion Array

After receiving the i512-SX expansion array, perform the following steps to ensure that it and other contents arrived safely.

1. Inspect the outer shipping container for any damage that may have occurred in shipping. Report any sign of damage to the appropriate shipping agency.
2. Remove the i512-SX expansion array and cables from the shipping container.

3. Save the shipping container, foam, and antistatic bags in case you have to return the iS512-SX expansion array. Returning the iS512-SX expansion array in any other container is not advised.
4. Check the contents against the items referenced on the packing list. If any item is missing or damaged, notify a sales representative and/or the shipping agency.

#### 4.5 Items Supplied by the User

Table 4-3 lists the additional items you must supply to perform the iS512-SX expansion array installation. All users must provide the items in the first row of Table 4-3. Rack-mount users must provide the additional items shown.

Table 4-3. User-Supplied Items for Installing the iS512-SX Expansion Array

User Category	User-Supplied Items
All Users	<ul style="list-style-type: none"> <li>▪ Two available AC outlets not controlled by a wall switch (for best results, the second power receptacle should be on a different circuit).</li> </ul>
Rack-Mount Users	<ul style="list-style-type: none"> <li>▪ A standard NEMA-compliant 19-inch rack (cables supplied for connections between the iS512 primary array and iS512-SX expansion arrays require all arrays to be located in close proximity to each other).</li> <li>▪ Additional mounting hardware for specific rack being used, if necessary.</li> </ul>

#### 4.6 Installing the iS512-SX Expansion Array

If the iS512-SX expansion array will be installed on a desktop or shelf, locate the array close to the iS512 primary array, with sufficient ventilation space between the expansion array and any other objects in the vicinity. Do not block the air vents on the front and back of the iS512-SX expansion array enclosure. Install the cables and power cords according to the procedures in the following sections.

If the iS512 primary array will be mounted in a rack, mount the iS512 -SX expansion array in the same rack, either above or below the primary array. For information about installing the system in a rack, refer to Appendix B and the documentation for the rack.



---

The rack cabinet must provide sufficient airflow to the front and back of the iS512-SX expansion array to maintain correct cooling. It must include ventilation sufficient to exhaust the heat generated by equipment installed in the rack.

---

## 4.7 Connecting to the iS512-SX Expansion Arrays to iS512-08 or iS512-10G

To connect the first two iS512-SX expansion arrays to the iS512-08 or iS512-10G primary array, use the following procedure (and refer to Figure 4-5).

1. Facing the rear of the primary array, connect one end of the supplied primary array to expansion chassis cable (shown below in **blue**) to the right expansion connector labeled **EXP0**. Secure the cable to the primary array using the thumbscrews and locking tabs.
2. Connect the other end of the primary array-to-expansion chassis cable to the **HOST** connector on the rear of the expansion array. Secure the cable to the expansion array using the thumbscrews and locking tabs.

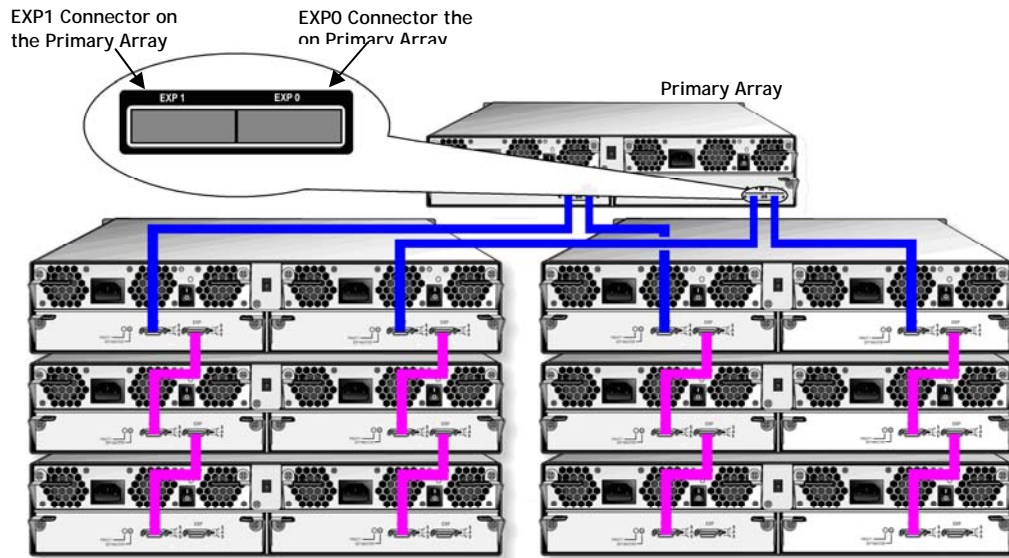

Figure 4-5. Connecting the iS512-SX Expansion Arrays to the iS512 Primary Array

3. To connect a second expansion array, connect one end of the second supplied primary array-to-expansion chassis cable to the left expansion connector labeled **EXP1** on the rear of the iS512 primary array and the other end to the **HOST** connector on the rear of the expansion array. Secure the cable connectors at both ends of the cable to the primary array and expansion array using the thumbscrews and locking tabs.
4. To attach additional expansion arrays, use a SAS-to-SAS expansion cable (shown above in **purple**) between the **EXP** connector on one expansion array and the **HOST** connector on the next expansion array. Up to three expansion arrays can be daisy-chained from each of the expansion ports on the iS512 primary array. For optimal performance, the number of expansion arrays should be evenly balanced across both of the expansion ports.
3. If your system is equipped with redundant controllers, repeat the above steps for the redundant controllers as shown in Figure 4-5.



The iS512 primary array has a mini-SAS connector, and the iS512-SX expansion chassis has a SAS connector. When making these connections, use the primary array-to-expansion chassis cable (mini-SAS to SAS) supplied with the iS512-SX. When connecting the third through sixth expansion arrays, you must obtain a separate SAS-to-SAS cable for each I/O module (available separately at no cost from iStor Networks).

#### 4.8 Connecting to the iS512-SX Expansion Arrays to iS512-04

To connect the first iS512-SX expansion array to the iS512-04 primary array, use the following procedure (and refer to Figure 4-6).

1. Facing the rear of the primary array, connect one end of the supplied primary array to expansion chassis cable (shown below in blue) to the right expansion connector labeled **EXP0**. Secure the cable to the primary array using the thumbscrews and locking tabs.
2. Connect the other end of the primary array-to-expansion chassis cable to the **HOST** connector on the rear of the expansion array. Secure the cable to the expansion array using the thumbscrews and locking tabs.

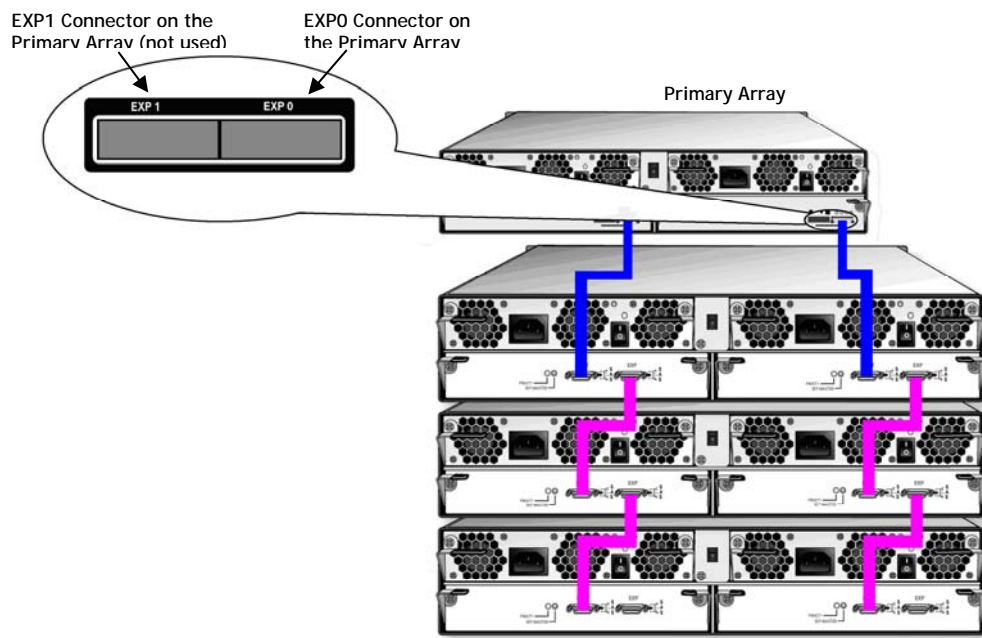

Figure 4-6. Connecting the iS512-SX Expansion Arrays to the iS512-04 Primary Array

3. To attach additional expansion arrays, use a SAS-to-SAS expansion cable (shown above in purple) between the **EXP** connector on one expansion array and the **HOST** connector on the next expansion array. Up to three expansion arrays can be daisy-chained from the expansion port on the iS512-04 primary array.
4. If your system is equipped with redundant controllers, repeat the above steps for the redundant controllers as shown in Figure 4-6.



---

The iS512-04 primary array has a mini-SAS connector, and the iS512-SX expansion chassis has a SAS connector. When making these connections, use the primary array-to-expansion chassis cable (mini-SAS to SAS) supplied with the iS512-SX. When connecting the second through fourth expansion arrays, you must obtain a separate SAS-to-SAS cable for each I/O module (available separately at no cost from iStor Networks).

---

## 4.9 Connecting the AC Power Cords

The iS512-SX expansion array has two power receptacles. Both must be used to connect the iS512-SX to an AC outlet:

1. Plug the female end of one power cord into one of the 3-pronged power connectors on the back of the iS512-SX expansion array. Plug the other end of the power cord into a working AC outlet that is not controlled by a wall switch.
2. Repeat the previous step using the second power cable and power receptacle on the iS512-SX expansion array.



---

For best practices, use both power supplies and connect the second power receptacle to a different circuit.

---

## 4.10 Powering-on the iS512-SX Expansion Array

To power-on the iS512-SX expansion array, turn on the rocker switches on both power supplies at the rear of the unit. When the iS512-SX expansion array powers-on, the following actions occur:

- The front panel **Power** LED turns green.
- The iS512-SX expansion array runs its power-on procedure, after which the **READY** LED on the right front bracket turns green

## Appendix A Replacing and Upgrading FRUs

This appendix describes how to replace or upgrade the Field Replaceable Units (FRUs) in the iS512 primary array and iS512-SX expansion array. FRUs that can be replaced or upgraded include:

- SATA and SAS drives
- Power supply modules
- Controller module (primary array only)
- I/O module (expansion array only)
- Connection of the serial port for diagnostics when working with iStor Support

## A.1 Installing or Replacing Drives

Before you install or replace drives, plan where you will be placing the disk drives. If an array will not be fully populated with drives, be sure the drive slots contain blank filler panels. For more information, see Figure 2-3 and Section 2.1.



---

Do not mix SAS and SATA drives in the same storage system.

---

To install a drive, use the following procedure.

1. On the front of the enclosure, select an open drive slot.
2. Select the right type of drive for this drive slot (see the figures above).
3. Hold the drive so the LEDs are on the left and the lever is fully open. Then slide the drive into the drive slot until the lever starts to close.

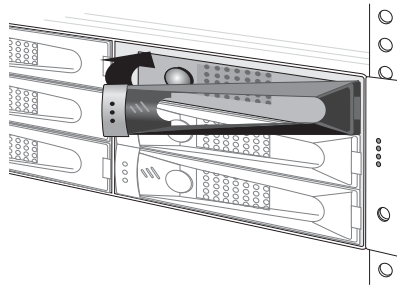

Figure A-1. Installing a Drive

4. Gently push the lever until it meets the latch on the left side of the drive slot and clicks into place.

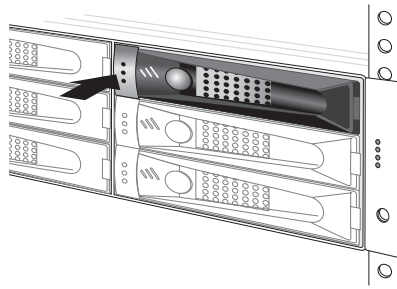

Figure A-2. Securing a Drive in the Slot

5. To install additional drives, repeat this procedure.



---

To maintain proper airflow and cooling, a drive or a blank drive filler must be installed in every slot of the enclosure.

---

## A.2 Replacing a Power Supply Module in the Primary or Expansion Array

The power supply and fan reside on the same module. Facing the back of the array, one power supply/fan module appears on the left side of the array and a second module appears on the right side. The procedure described below can be used for either power supply module.



---

The fan module continues to work even if the power supply fails. Therefore, to ensure proper ventilation, leave the faulty power supply installed in the system until you are ready to replace it. For hot-swap operations, we recommend you complete the replacement procedure within 2 minutes.

---

To replace a power supply and fan module:

1. Optionally, power down the iS512 primary array and remove the power cords from the back panel.
2. Squeeze down on the top of the levers on either side of the module and pull down to disengage the module, then pull the module straight out of the enclosure.
3. Install a replacement module by keeping the levers on the left and right sides down, then slide the module into the enclosure until you feel it engage into place.
4. Replace the power cords and power on the iS512 primary array.

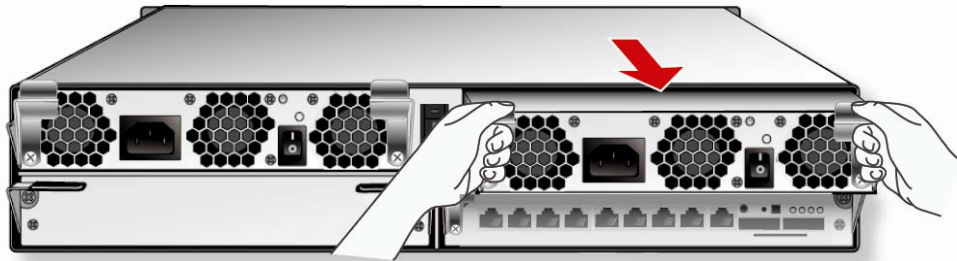

Figure A-3. Removing a Power Supply and Fan Module (right-most module shown)

### A.3 Replacing the Controller Module on the Primary Array

Use the following procedure to replace a controller module on the primary array.

1. Power down the iS512 primary array and remove the power cords from the back panel.
2. Squeeze down on the top of the levers on either side of the controller module on the primary array and pull down to disengage the module, then pull the module straight out of the enclosure.
3. Install a replacement controller module in the primary array by keeping the levers on the left and right sides down, then slide the module into the enclosure until you feel it engage into place.
4. Replace the power cords and power on the iS512 primary array.

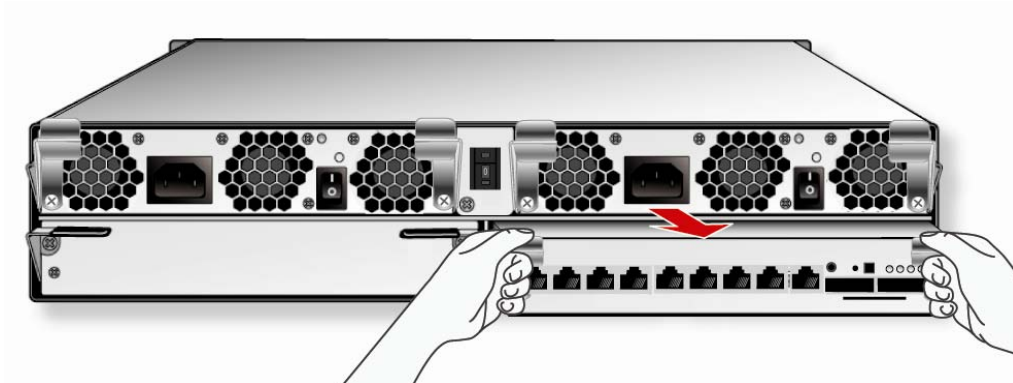

Figure A-4. Removing the Controller Canister on the Primary Array (Slot #0 shown)

## A.4 Replacing the I/O Module on the Expansion Array

Use the following procedure to replace the I/O module on the expansion array.

1. Power down the iS512 primary and iS512-SX expansion array and remove the power cords from the back panel.
2. Squeeze down on the top of the levers on either side of the I/O module on the iS512-SX expansion array and pull down to disengage the module, then pull the module straight out of the enclosure.
3. Install a replacement I/O module in the expansion array by keeping the levers on the left and right sides down, then slide the module into the enclosure until you feel it engage into place.
4. Replace the power cords and power on the iS512 primary array and expansion array.



Figure A-5. Removing the I/O Module on the Expansion Array (Slot #0 shown)

## A.5 Connecting to the Diagnostic Serial Port

The iS512 storage arrays have a 115.2 Kbps RS-232-C stereo mini-jack connector on the right side of the rear panel (see Figure A-5). Using this port, you can:

- Reset the array to factory default settings (this deletes all custom settings, including all accounts you may have set up, except the default admin account)
- Reboot or shutdown the array
- Set the out-of-band port configuration

This port also lets you monitor the array's power-on self test.

The arrays come with a cable for connecting a computer or server (PC) to the array's diagnostic port. The cable has a stereo mini-jack connector on one end that attaches to the array's diagnostic port and a DB-9 connector on the other end that attaches to a PC.

The PC must have a terminal-emulation program (such as HyperTerminal) installed. The program should be configured as follows:

- Baud rate: 115,200 bps
- Data bits: 8
- Parity: None
- Stop bits: 1
- Hardware handshake: None

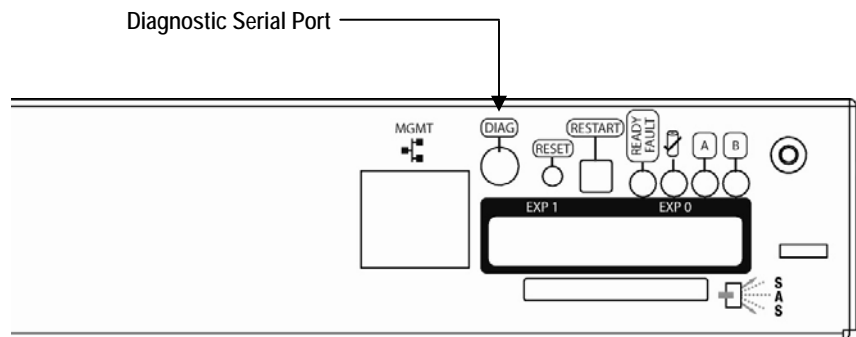

Figure A-6. Diagnostic Serial Port on Array Rear Panel

To reset or reboot the array or set the out-of-band port configuration:

1. Connect the diagnostic port to a PC.
2. Start your terminal-emulation program and configure it as indicated above.
3. When prompted, login with your username and password. The following menu appears.

```
iStor Networks, Inc. - integraStor
1) Reset to factory defaults
2) Reboot or shutdown the system
3) Set the out-of-band port configuration
4) Quit
Enter number of desired option:
```

4. Type the number that corresponds to the action you want to perform.
5. Follow the screen prompts to complete the activity.

This Page Left Intentionally Blank

## Appendix B Installing the System in a Rack

This appendix describes how to install the iS512 primary and expansion arrays in a rack. The rack-mount kit comes with the following items:

- Two long main left and right rails
- Two medium left and right rear rails
- Two short left and right rear rails
- Ten long screws and four short screws
- Ten spring-loaded cage nuts
- Ten E-shaped nuts

Each side of the rack mount is composed of a main rail and either a medium or a short rear rail secured by two long screws on the front and rear of the rack. A third long screw on the front of the rack secures the array to the rack.



---

To facilitate lifting and installing the array, we recommend that you remove all drives from the array before you install it in the rack. After the array is installed in the rack, you can install the drives in the array.

---

To install your array into a rack:

1. Select the locations in the rack where you will be installing the rails that will support the primary array and any expansion arrays (if appropriate). When selecting a location, note the location of the three mounting holes on the rack's front vertical supports and the two mounting holes on the back vertical supports, as shown in the following figure. These locations will become important when you secure the rails and the array to the rack.

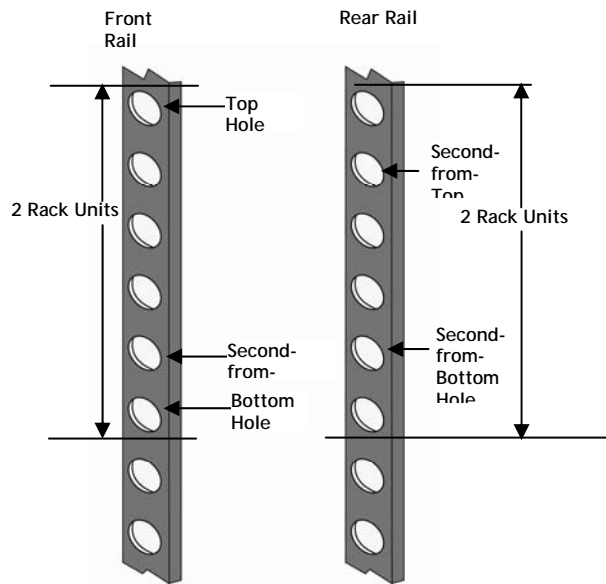

Figure B-1. Example of Mounting Hole Locations on the Front and Rear Rack Rails

2. Assemble the rails that will accommodate the array in the rack. The long main left and right rails are used in all installations (these rails have a bottom piece on which the array sits in the rack). However, you must determine whether to use the two medium rear rails or the two short rear rails based on the depth of your rack. Then assemble the main and rear rails together at the exact length to match the distance between the front and rear vertical supports of the rack.
3. After determining which rear rails to use, orient the left rear rail so its flange faces outwardly to the left and orient the left main rail so the bottom lip (which will support the array) protrudes inwardly, as shown in the following figure. Then secure the left rear rail to the left main rail using two of the supplied short screws (the screws go through the slots in the rear rail and into the threaded section of the long rail, as shown in the following figure).

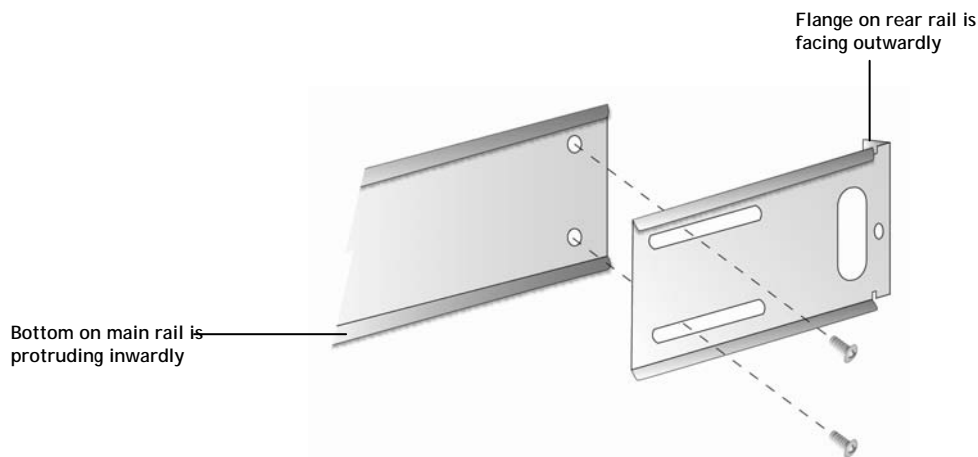

Figure B-2. Securing the Main and Rear Rails

4. Orient the right rear rail so its flange faces outwardly to the right and orient the right main rail so the bottom lip protrudes inwardly. Then secure the right rear rail to the right main rail using the remaining two long or short screws (the screws go through the slots in the rear rail into the threaded section of the long rail).
5. Orient the right rear rail so its flange faces outwardly to the right and orient the right main rail so the bottom piece protrudes inwardly. Then secure the right rear rail to the right main rail using the remaining two short screws (the screws go through the slots in the rear rail into the threaded section of the long rail).
6. Insert the rails into the rack and secure the rails to the vertical supports using one of the following methods:
  - If the rack has square punchout holes, secure the rails using the supplied long screws with the supplied snap-in spring-loaded cage nuts. Attach the nuts to the three rail holes (top, bottom, and second-from-the-bottom) on the front left and right sides of the rack. Then attach nuts to the two middle holes on the rear of the rack.
  - If the rack holes are unthreaded circular holes, use the long screws with the supplied E-shaped nuts. Attach E-shaped nuts to the three rail holes (top, bottom, and second-from-the-bottom) on the front left and right sides of the rack. Then attach E-shaped nuts to the two middle holes on the rear of the rack.

- If the rack has round and threaded holes, secure the rails using the supplied long screws only (there is no need to use the snap-in spring-loaded cage nuts and the E-shaped devices).
7. Secure the rails to the rack by inserting screws in the top and bottom holes on the left and right sides on the front of the rack (as shown in the following figure). Do not insert screws into the second-from-the-bottom hole at this time.

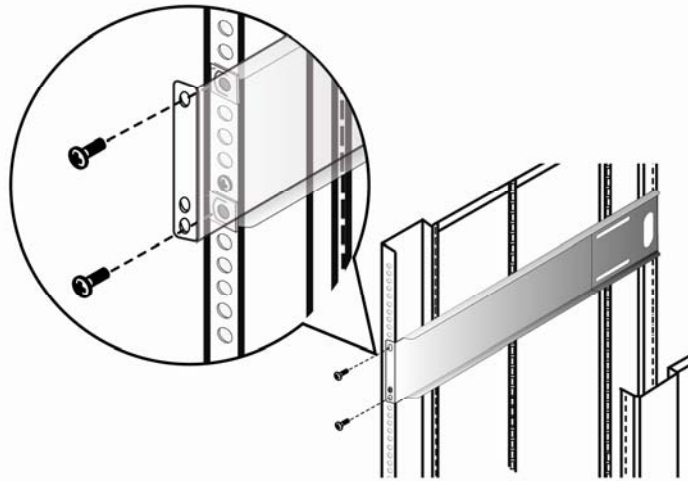

Figure B-3. Securing the Rails to the Rack

8. Insert screws into the middle two rear rail holes.
9. Verify that the rails are installed securely in the rack.
10. Carefully slide the array onto the rails, pushing it back until the flanges on the front of the chassis meet the vertical supports.

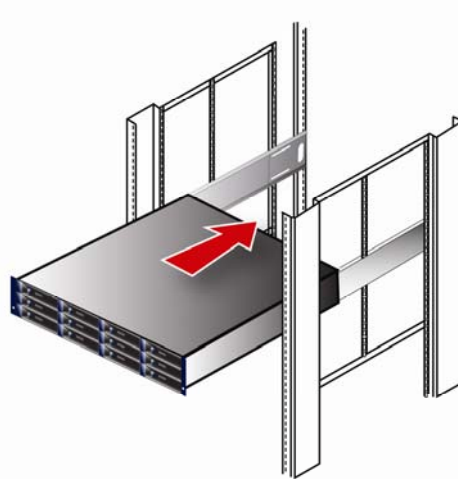

Figure B-4. Sliding the Array onto the Rails

11. Locate the second-from-the-bottom hole on the front right side of the rack. This hole should be aligned with a hole in the flange or "ear" on the right front of the array. Place a screw in the hole in the array, then insert a screwdriver through the hole in the front flange of the array and tighten the screw to secure the array to the vertical supports, as shown in the following figure. Repeat this step using another screw and the second-from-the-bottom hole on the left side of the rack.

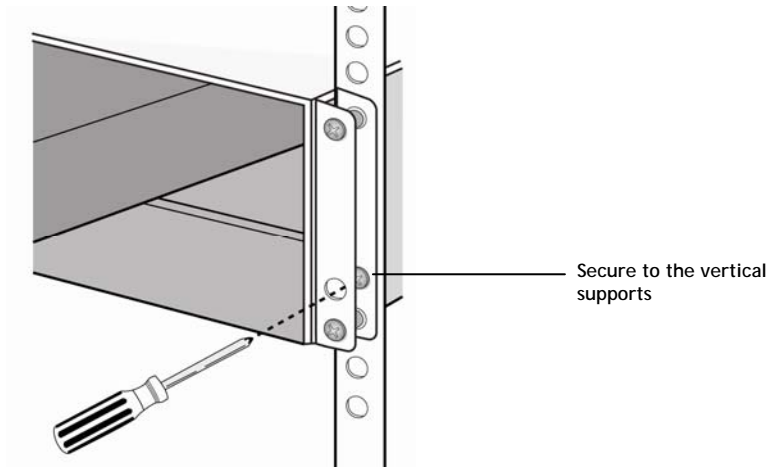

Figure B-5. Securing the Array to the Rack

# Index

- Benefits, 3
  - Connecting
    - power cords on the iS512 primary array, 21
    - power cords on the iS512-SX expansion array, 30
  - Connecting to
    - host iSCSI data ports on the iS512 primary array, 18
    - iS512 primary array, 28, 29
    - management port on the iS512 primary array, 19
  - Controller module, replacing, 34
  - Conventions, iv
  - Diagnostic serial port, 36
  - Drive carrier status LEDs
    - iS512 primary array, 7
    - iS512-SX expansion array, 25
  - Drive status LEDs
    - iS512 primary array, 6
    - iS512-SX expansion array, 25
  - Drives
    - installing or replacing, 32
  - Enclosure
    - damage to iS512 primary array, 18
    - damage to iS512-SX expansion array, 26
    - front panel, 24
      - iS512 primary array front panel, 6
      - iS512 primary array rear panel, 8
      - iS512-SX expansion array rear panel, 26
  - Enclosure LEDs
    - iS512 primary array, 7
    - iS512-SX expansion array, 24
  - Features, 3
  - Front panel components
    - iS512 primary array, 6
    - iS512-SX expansion array:, 24
  - Gigabit iSCSI data port connections on the iS512 primary array, 18
  - I/O module, replacing, 35
  - Installation
    - iS512 primary array
      - connecting the power cords, 21
      - connecting to iSCSI data ports, 18
      - connecting to management port, 19
      - safety considerations, 17
      - unpacking, 18
      - user-supplied items, 18
    - iS512-SX expansion array
      - connecting the power cords, 30
      - connecting to the iS512 primary array, 28, 29
      - desktop or shelf, 27
      - safety considerations, 26
      - unpacking, 26
      - user-supplied items, 27
    - site considerations, 16
  - Installing
    - drives, 32
    - power supply, 33
  - iS512
    - benefits, 3
    - features, 3
    - models, 2
    - sample configuration, 4
    - system overview, 4
  - iS512 primary array
    - connecting to iSCSI data ports, 18
    - drive carrier status LEDs, 7
    - drive status LEDs, 6
    - front panel components, 6
      - lever release button, 6
      - port activity LEDs, 11
      - port speed LEDs, 11
      - power-on, 22
    - rear panel components, 8
    - rear panel LEDs, 12
    - unpacking, 18
  - iS512 primary array enclosure LEDs, 7
  - iS512-SX expansion array
    - front panel components, 24
  - iS512-SX expansion array enclosure LEDs, 24
  - iS512-SX expansion array drive status LEDs, 25
  - iS512-SX expansion array lever release button, 25
  - iS512-SX expansion array drive carrier status LEDs, 25
  - iS512-SX expansion array drive status LEDs, 25
  - iS512-SX expansion array lever release button, 25
  - iS512-SX expansion array rear panel components, 26
  - iS512-SX expansion array unpacking, 26
  - iS512-SX expansion array power-on, 30
- LEDs
  - drive carrier status on iS512 primary array, 7
  - drive carrier status on iS512-SX expansion array, 25

- on iS512 primary array enclosure, 7
- on iS512-SX expansion array enclosure, 24
- port activity on iS512 primary array, 11
- port speed on iS512 primary array, 11
- rear panel on iS512 primary array, 12
- Lever release button
  - iS512 primary array, 6
  - iS512-SX expansion array, 25
- Management port connection on the iS512 primary array, 19
- Models, 2
- Port activity LEDs
  - iS512 primary array, 11
- Port speed LEDs
  - iS512 primary array, 11
- Power cord connections on the iS512 primary array, 21
- Power cord connections on the iS512-SX expansion array, 30
- Power supply, installing or replacing, 33
- Powering-on
  - iS512 primary array, 22
  - iS512-SX expansion array, 30
- Rear panel components
  - iS512 primary array, 8
  - iS512-SX expansion array, 26
- Rear panel LEDs
  - iS512 primary array, 12
- Replacing
  - controller module on the primary array, 34
  - drives, 32
  - I/O module on the expansion array, 35
  - power supply, 33
- Safety considerations
  - iS512 primary array, 17
  - iS512-SX expansion array, 26
- Serial port for diagnostics, 36
- Site considerations, 16
- System overview, 4
- Typographic conventions, iv
- Unpacking
  - iS512 primary array, 18
  - iS512-SX expansion array, 26
- Upgrading
  - drives, 32
- User-supplied items
  - iS512 primary array, 18
  - iS512-SX expansion array, 27